

# Installation And Operation Manual



**SUPERCHANGER<sup>®</sup>**  
PLATE & FRAME HEAT EXCHANGER



# TABLE OF CONTENTS

EQUIPMENT LOG SHEET	3	SERVICING	31
IDENTIFYING YOUR SUPERCHANGER® UNIT	3	Shutting Down the Unit	31
PLATE DESCRIPTION AND CONSTRUCTION	4	Disassembly Procedures	31
Plate Details	5	Removal of Plates	31
Unit Part Numbers	6	Replacing Plates	32
Plate Material and Date of Manufacture Data	7	Replacing Gaskets	32
Model Nomenclature	8	Removing Old Gaskets	32
Frame Pressure Ratings	8	Installing Continuously Glued Gaskets	33
Condensed Unit Specifications	9	Installing Spot-Glued Gaskets	34
Plate Pack Widths	10	Installing SUPERLOCK® Snap-In Gaskets	35
Plate Pack Tightening Dimensions	10	Installing Teflon Encapsulated Gaskets and Unit Assembly	35
Plate Designations	11	Installing Clip-On Gaskets	36
Drawings	12	Steps for Manual Cleaning of Plates	37
Element Composition Diagram	12	Plate Cleaning Tips	38
Plate Hole Designation for UX, SX, GC and GF Series	13	Cleaning-In-Place (CIP)	38
PASS AND FLOW ARRANGEMENT	14	Back Flushing and Strainers	39
Pass Arrangement	14	Cleaning Guidelines	39
Flow Arrangement	14	TRUBLESHOOTING	40
Drains	15	Leakage Between the Plate Pack and the Frame	41
Connecting “C” Frames	17	Leakage Between the Nozzle and the End Frame	41
PLATE STYLES	18	Leakage Between the Plates to the	
Drawings	19	Outside of the Unit	42
Four-Plate Sequence	20	Mixing of Fluids	42
Multi-Pass Units	20	Increase in Pressure Drop or a Reduction	
GASKET DATA	21	in Temperature Reading	43
Gaskets—Glued	21	How to Find a Defective Plate With Through Holes	43
Gaskets—Glueless	22	STORAGE PROCEDURES	44
Gasket Storage Procedures	23	MISCELLANEOUS INSTRUCTIONS	45
Mixed Gasket Materials	24	General Maintenance	45
GX Gluing Codes	26	Ordering Parts	45
GX Start and End Plate Explanations	27	Returned Material	45
INSTALLATION	28	Damaged Shipments	45
Tightening the Plate Pack	29	Additional Information	45
Tightening Sequences	30	AUTHORIZED SERVICE CENTERS	46
Precautions Prior to Start-Up	30		

# EQUIPMENT LOG SHEET

You will need the information shown in the table below whenever you contact the factory for service. Upon delivery of your SUPERCHANGER unit(s), be sure to record the information from the Data Plate on each unit in case the nameplate is destroyed, lost or becomes illegible.

Equipment Tag #	Serial #*	Drawing #*	Model*

\* Tranter must have serial or drawing number to properly identify your equipment.

For PHE parts, service or performance ratings, contact one of Tranter’s authorized Service Centers (see full information for contacting on page 46).

## IDENTIFYING YOUR SUPERCHANGER® UNIT

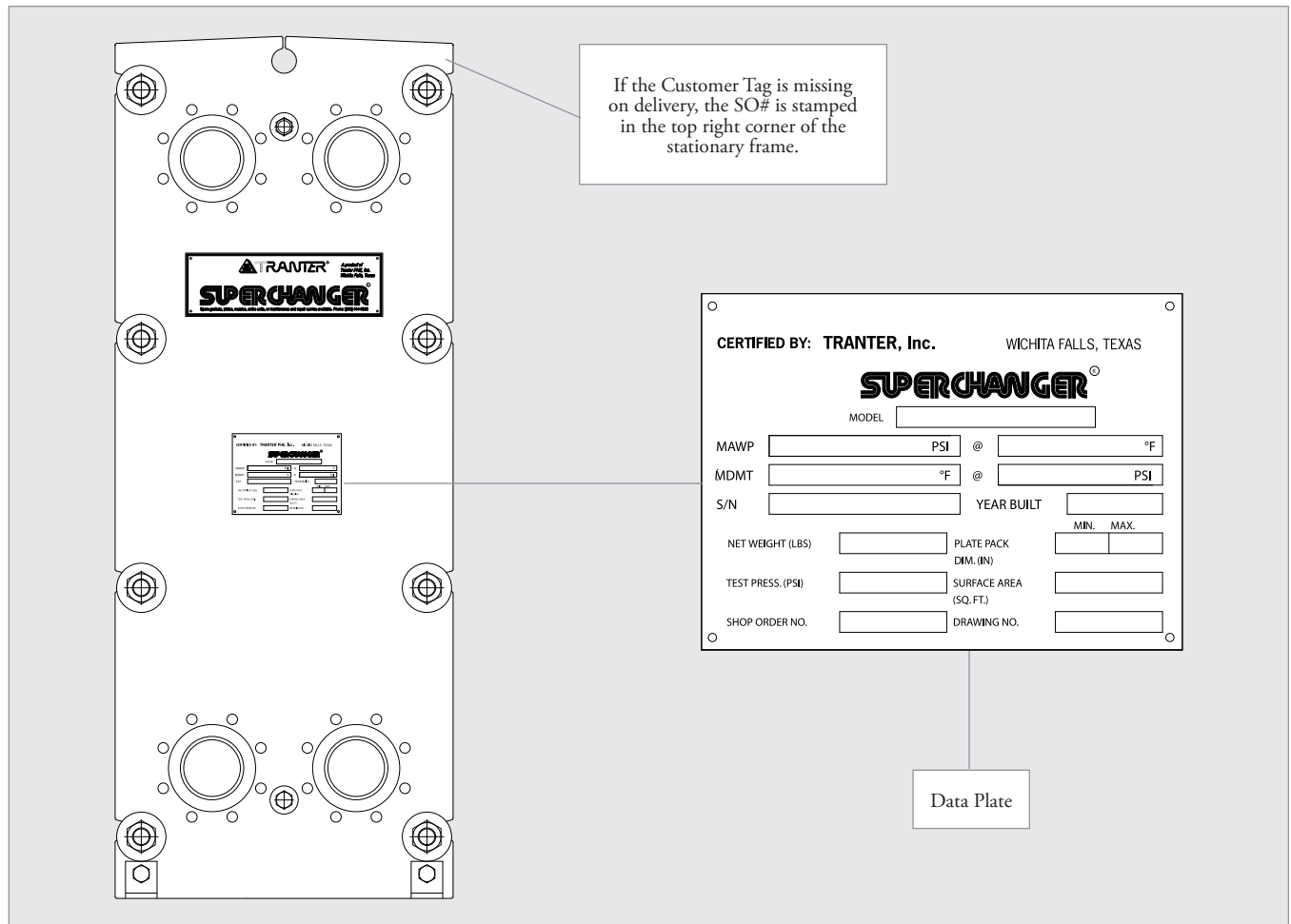

Figure 1  
 A data plate like the one shown on the picture above is fixed to the stationary frame of the unit and provides the following information. This information is helpful when contacting the factory.

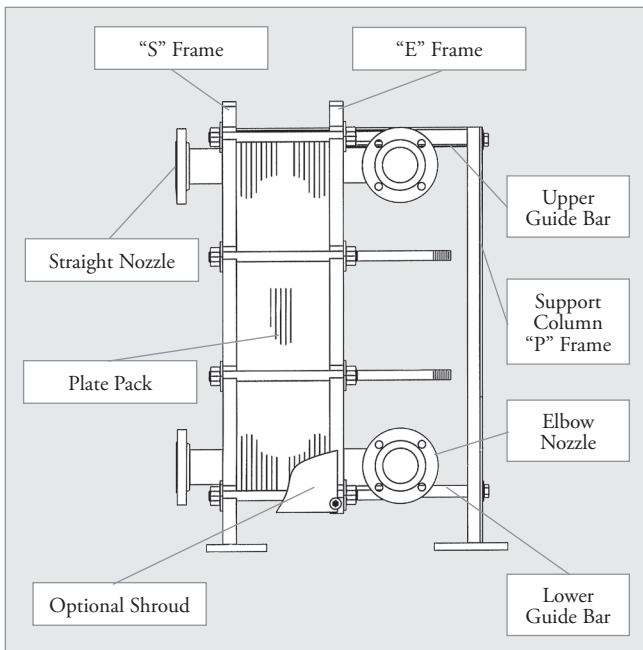

Figure 2  
Superchanger Frame, Models HP, UP, SP, MP and FP.

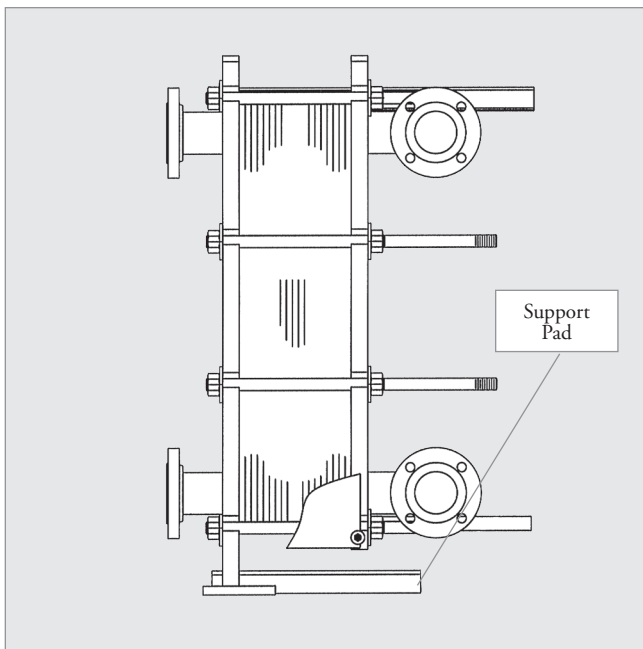

Figure 3  
Superchanger Frame, Models HJ, UJ, SJ and MJ.

## PLATE DESCRIPTION AND CONSTRUCTION

SUPERCHANGER plate corrugations are available in four patterns. Depending on the applications, the GF, UX, SX, GC and GX Series plates are used to achieve maximum heat transfer.

**UX, SX and GC Series plates:** Herringbone (chevron) pattern is ideally suited for handling aqueous solutions.

**GF Series:** Wide gap and parallel (washboard) patterns are designed for applications where there are high viscosity fluids or fluids containing fibers or coarse particles.

**GX Series:** An asymmetrical four quadrant plate suited for low viscosity and close temperature approach applications or processes involving two vastly different flow rates. It is also well suited for equal flows and close approach.

All plates are manufactured from die-formed sheet metal in virtually any material that can be cold worked, such as stainless steel, titanium, Alloy C-276, Alloy-20, etc. There are grooves around the circumference of the plates which accept the sealing gasket and also add reinforcement because of the ribbed edges. Fluid passage holes are pierced at the corners of each plate. The number and location of the holes is dependent upon the design conditions.

The gaskets are single piece, molded construction, and generally bonded to the plates with Pliobond 30 adhesive. The gasket material is selected for compatibility with the fluids being processed and the operating temperatures.

Each plate also contains flow directors at the top and bottom of the heat transfer surface in the port hole areas, which evenly distribute the fluids. Some plates require a hanger, which attaches the plate to the upper guide bar. For most models, the upper guide bar is the plate's sole support member in the frame, while the lower guide bar serves as an alignment member in all plates except the UXP-005 and the UXP-001, which are supported by the lower guide bar. See Figures 4 through 7 and Tables 1a and 2 for specific models.



# Plate Details

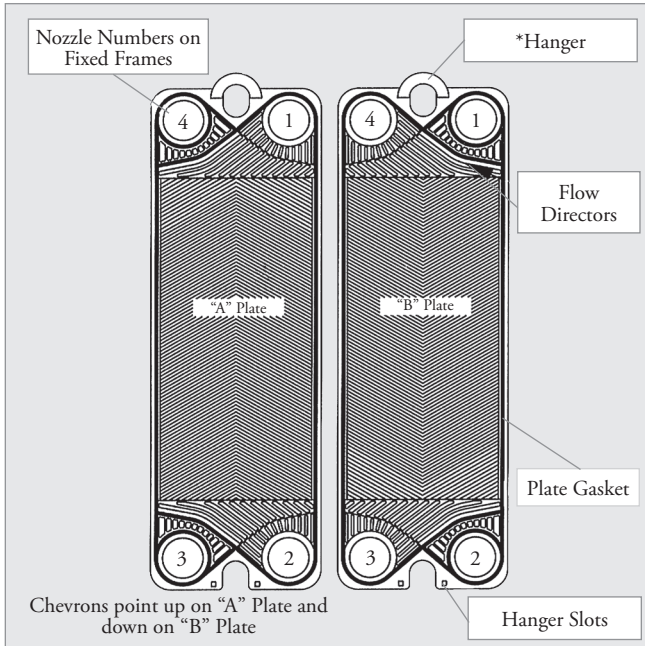

**Figure 4**  
 Typical UX, SX or GC Series (herringbone) plate with gasket and hanger. Note that the chevron angle for the herringbone plate can differ on various models.

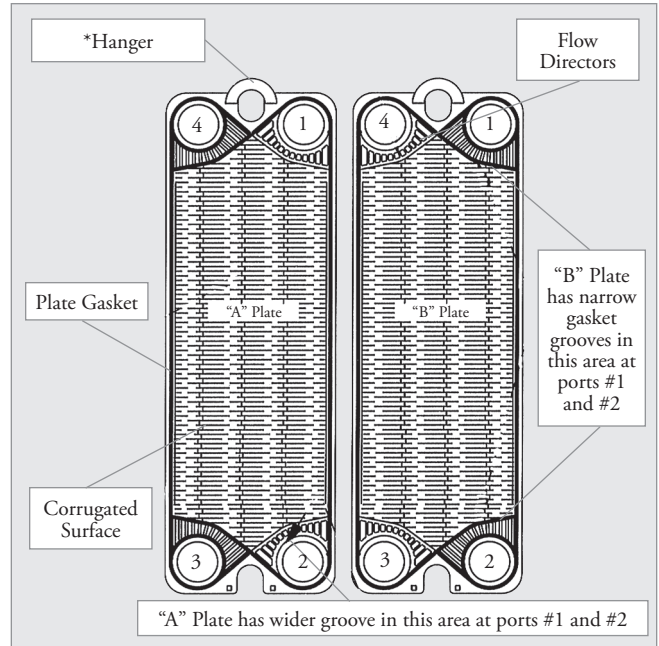

**Figure 5**  
 Typical GF Series (washboard) plate with gasket and hanger.

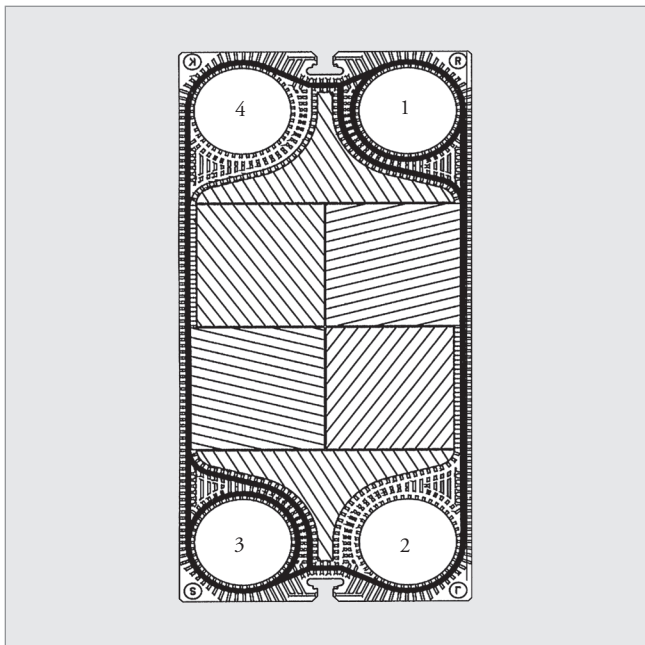

**Figure 6**  
 Typical GX plate with gasket. Note that the chevron angle for the herringbone plate can differ on various models.

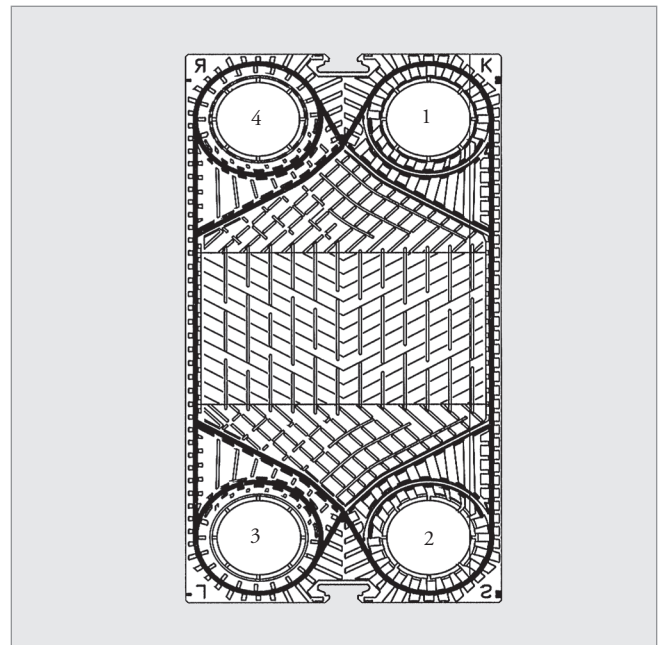

**Figure 7**  
 Typical GF (wide gap) plate with gasket.

## Unit Part Numbers

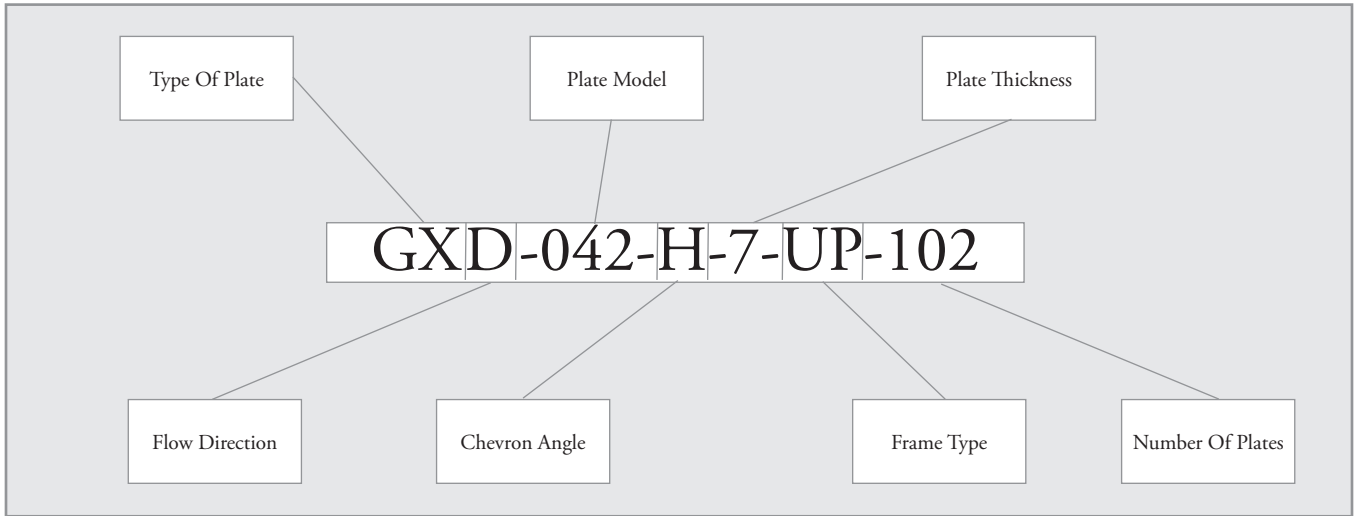

Figure 8  
 Typical SUPERCHANGER model number, in this case a diagonal flow GX-42 unit with glued gaskets, 0.7 mm thick high-theta plates, a UP frame and 102 plates.

Figure 8 displays a typical SUPERCHANGER unit part number. The first entry represents the plate style (two-letter code) and flow, such as:

- GX Gasketed Ultraflex / Gasket groove in the neutral plane
- GC Gasketed Conventional / Gasket groove in the bottom plane
- GD Gasketed Double Wall
- GW Gasketed Semi Welded
- GF Gasketed Free Flow (Wide Gap and Washboard)
- GM Gasketed Mechanical Glue (Snap-In gaskets)
- GL Gasketed Conventional / Gasket groove in the neutral plane

The second entry (third character) represents the flow; D for diagonal and P for parallel.

The third entry (three-digit code) represents the plate model or surface area.

The fourth entry represents the plate profile angle, or theta:

- H (high)
- L (low)
- M (mixed)
- A (30°+45° for UXP-960)
- Z (45°+60° for UXP-960)

The fifth entry represents the plate thickness:

- 5 (0.5 mm)
- 6 (0.6 mm)
- 7 (0.7 mm)
- 8 (0.8 mm)
- 9 (0.9 mm)
- 0 (1 mm)

The sixth entry shows the frame type (HP, UP, etc.).

The final entry (three-digit code) represents the plate count.

## Plate Material and Date of Manufacture Data

All plates are stamped with identification numbers. The numbers are located on both ends of the plates as indicated in the sketches below. The heat number, material and month and year of manufacture can be determined from these numbers.

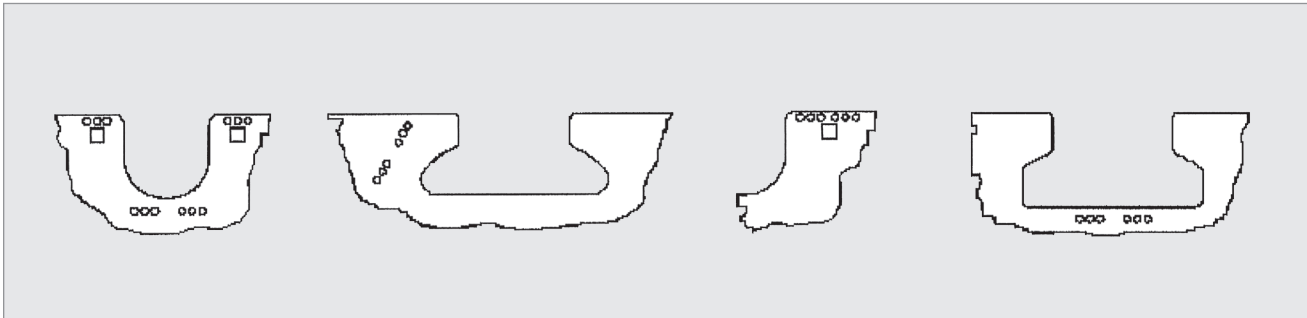
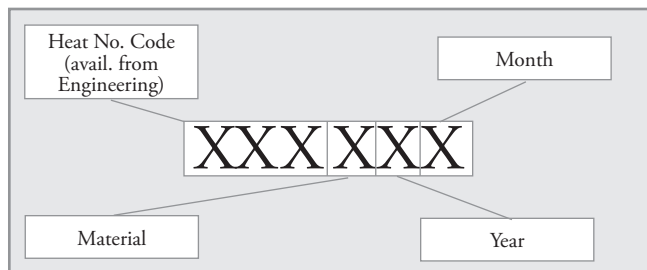
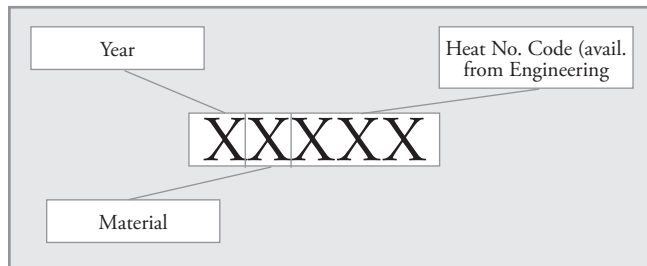

Figure 9  
General locations of code stamping for various plate models.

### Six-Digit Codes



### Five-Digit Codes



### P-Prefix Codes

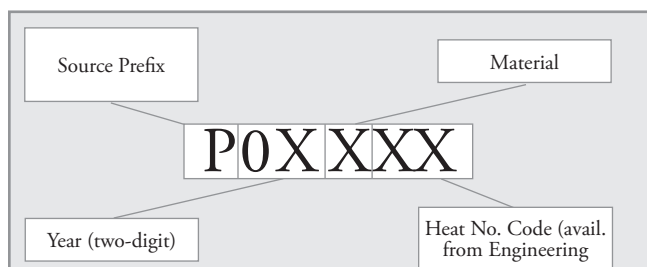

Table 1 Plate Codes

	Six-Digit	Five-Digit or P-Prefix
<b>Material</b>		
0	Other (Nickel, 317 SS, 317L SS, etc.)	AISI 304
1	304 SS	AISI 316
2	316 SS	AISI 316L
3	Titanium	654 SMO
4	316L SS	254 SMO or other SS
5	Hastelloy-C-276	Titanium Grade 1
6	Incolloy 825	Titanium Grade 2
7	Monel 400	Hastelloy-C-276
8	316 High Moly	G-30
9	304L SS	Other materials
<b>Year Of Manufacture</b>		
8 or 08		1998
9 or 09		1999
0 or 00		2000
1 or 01		2001
2 or 02		2002
3 or 03		2003
4 or 04		2004
5 or 05		2005
6 or 06		2006
7 or 07		2007
<b>Month Of Manufacture</b>		
1	Jan/Feb	NA
2	Mar/Apr	NA
3	May/June	NA
4	July/Aug	NA
5	Sept/Oct	NA
6	Nov/Dec	NA



## Model Nomenclature

If your unit was manufactured before July 1, 2002, use Table 1a to determine the current plate style nomenclature for your unit. Note

the port numbering has changed to the new design (see page 13).

**Table 1a Updated Nomenclature Codes**

Old Name	New Name
<b>Glued Gasket Models</b>	
GC-12	GCD-012
GC-30	GCD-030
GC-48	GCD-048
GC-50	GCD-050
GC-26	GCP-026
GC-28	GCP-028
GC-51	GCP-051
GC-60	GCP-060
S3	GFP-030
S8	GFP-080
TW-05	GFP-057
TW-10	GFP-097
TW-18	GFP-187
TD-10	GCD-010
TP-10	GCP-010
GW-81	GWP-081
GW-82	GWP-082
GW-83	GWP-083
WH-040	GWP-400
WX-050	GWP-500
UFX-6/GX-6	GXD-006
GX-7	GXD-007
UFX-12/GX-12	GXD-012
UFX-18/GX-18	GXD-018
UFX-26/GX-26	GXD-026
UFX-37/GX-37	GXD-037
UFX-42/GX-42	GXD-042
UFX-51/GX-51	GXD-051
UFX-60/GX-60	GXD-060
UFX-64/GX-64	GXD-064
UFX-85/GX-85	GXD-085
UFX-91/GX-91	GXD-091
UFX-100/GX-100	GXD-100
Old Name	New Name

<b>Glued Gasket Models</b>	
UFX-118/GX-118	GXD-118
UFX-140/GX-140	GXD-140
UFX-145/GX-145	GXD-145
UFX-180/GX-180	GXD-180
UFX-205/GX-205	GXD-205
UFX-265/GX-265	GXD-265
UFX-325/GX-325	GXD-325
07S	SXP-070
14S	SXP-140
SX41	SXP-400
UX-05	UXP-005
UX-01	UXP-010
06T	UXP-060
UX-10	UXP-100
11T	UXP-110
UX-20	UXP-200
UX-40	UXP-400
UX-81	UXP-801
UX-83	UXP-802
UX-90	UXP-900
LP-80	UXP-960
<b>Snap-In Gaskets</b>	
GC-26	GMP-026
UX-05	UMP-005
UX-01	UMP-010
UX-20	UMP-200
UX-40	UMP-400
06T	UMP-060
TP-10	GMP-010
TD-10	GMD-010
<b>Double Wall</b>	
GX-42	GDD-042
UX-01	UDP-010

## Frame Pressure Ratings

**Table 1b Frame Pressure Ratings**

FRAME TYPE	NOMINAL ASME CODE PRESSURE RATINGS	
	Design Pressure, (psig)	Test Pressure, (psig)
NJ/NP/VJ/VP	Non-code; contact factory	Non-code; contact factory
HJ/HP	100	130
UJ/UP	150	195
SJ/MJ/SP/MP	300	390
FP	350	455

Standard unit pressure ratings are shown. Contact the factory for higher design pressures, up to 400 psig, depending upon the application.



# Condensed Unit Specifications

**Table 2** Condensed Unit Specifications

Model	Nominal Frame Dimensions		Connection (in.)	Max. Flow (gpm)	Channel Volume Between Plates (gal)		
	Height (in.)	Width (in.)			Wide	Medium	Narrow
GXD-007	37	8-1/4	1	75	NA	0.0423	NA
GXD-012	39	14	2	292	NA	0.0872	NA
GXD-018	48	14	2	292	NA	0.124	NA
GXD-026	54	22	2, 4	1171	NA	0.227	NA
GXD-042	71	22	2, 4	1171	NA	0.351	NA
GXD-051	72	27	4, 6	2264	NA	0.444	NA
GXD-037	60	27	4, 6	2769	NA	0.246	NA
GXD-064	79	27	4, 6	2769	NA	0.423	NA
GXD-091	98	27	4, 6	2769	NA	0.6	NA
GXD-118	117	27	4, 6	2769	NA	0.777	NA
GXD-060	69	38	4, 6, 8	4755	NA	0.502	NA
GXD-100	92	38	4, 6, 8	4755	NA	0.845	NA
GXD-140	115	38	4, 6, 8	4755	NA	1.162	NA
GXD-180	138	38	4, 6, 8	4755	NA	1.479	NA
GXD-085	81	50	10, 12, 14	10471	NA	0.88	NA
GXD-145	104	50	10, 12, 14	10471	NA	1.334	NA
GXD-205	127	50	10, 12, 14	10471	NA	1.788	NA
GXD-265	149	50	10, 12, 14	9183	NA	2.243	NA
GXD-325	172	50	10, 12, 14	9183	NA	2.695	NA
UXP-005	24	12	1, 2	265	NA	0.06	NA
UXP-010	31	12	1, 2	292	NA	0.08	NA
UXP-100	45	17	2, 3	520	NA	0.13	NA
GFP-030	58	22	2, 3, 4	1060	NA	0.4	NA
UXP-200	62	24	2, 3, 4	1060	NA	0.34	NA
UXP-060	74	32	4, 6, 8	3825	NA	0.67	NA
SXP-070	71	36	4, 6, 8	4754	NA	0.52	NA
GFP-080	85	30	4, 6, 8	3450	NA	0.9	NA
UXP-400	85	32	4, 6, 8	3825	NA	0.87	NA
SXP-400	83	36	4, 6, 8	4754	NA	0.63	NA
UXP-110	106	32	4, 6, 8	3825	NA	1.21	NA
SXP-140	103	36	4, 6, 8	4754	NA	0.81	NA
UXP-801	105	54	10, 12, 14	11200	NA	2.40	NA
GCP-010	38	13	1, 2	292	NA	0.1135	NA
GCP-016	39	14	2, 5	292	NA	0.063	NA
GCP-026	54	22	2, 3, 4	1171	NA	0.2642	NA
GCP-028	31	7	1	75	NA	0.4	NA
GCP-051	72	27	4, 6	2324	NA	0.55	NA
GCP-060	69	38	4, 6, 8	4755	NA	0.783	NA
GFP-057	71	35	4, 6, 8	4755	2.36	2	1.63
GFP-097	88	35	4, 6, 8	4755	3.23	2.61	1.99
GFP-187	126	35	4, 6, 8	4755	5.08	3.92	2.76
GLP/GLD-013	39	14	2.5	475	NA	0.087	NA
GL-230	121	66	20	23465	NA	3.33	NA
GL-330	145	66	20	23465	NA	3.78	NA
GL-430	169	66	20	23465	NA	4.65	NA



## Plate Pack Widths

“A” Dimension for standard thickness materials

Calculating the “A” dimension (Plate Pack Width in Inches) for various SUPERCHANGER Models can be accomplished by using the formulas indicated in Table 3. N = Number of Plates.

PLATE DESIGNATION, p	PLATE THICKNESS, t
4	0.015748
5	0.019685
6	0.023622
7	0.027559
8	0.031496
0	0.039370

N = Number of Plates

p = Plate Thickness Designation

t = Plate Thickness in Inches

Please contact Tranter for the “A” Dimension when other plate thicknesses are involved.

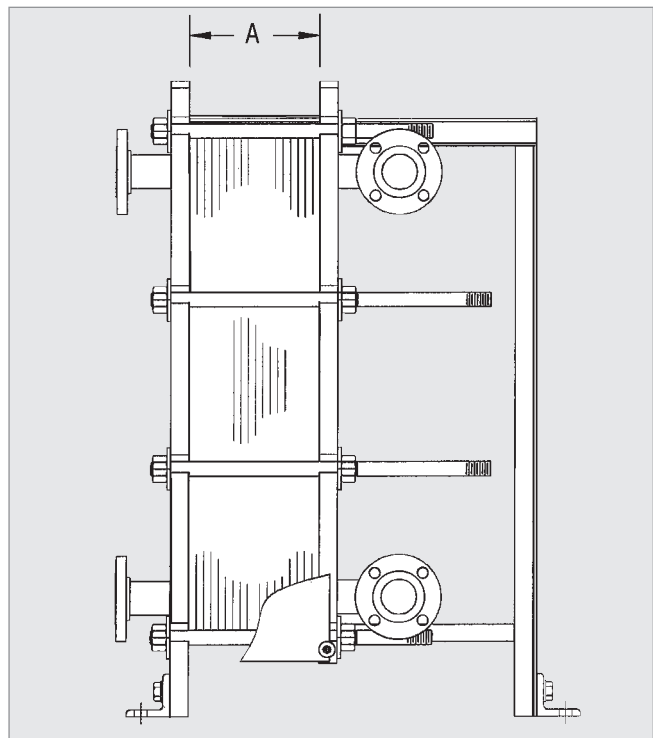

Figure 10  
Plate thicknesses.

## Plate Pack Tightening Dimensions

Table 3 Plate Pack Tightening Dimensions

Plate Type	A Max.* (in.)	A Min.* (in.)	Plate Type	A Max.* (in.)	A Min.* (in.)
UXP-005	(t + 0.102362) N	(t + 0.094488) N	GXD-026, GXD-042	(t + 0.13441) N	(t + 0.12541) N
UXP-010	(t + 0.102362) N	(t + 0.094488) N	GXD-037, -064, -091, -118	(t + 0.11821) N	(t + 0.11021) N
UXP-100	(t + 0.0944) N	(t + 0.0866) N	GXD-051	(t + 0.13441) N	(t + 0.12541) N
UXP-200	(t + 0.108268) N	(t + 0.102362) N	GXD-060, -100, -140, -180	(t + 0.13441) N	(t + 0.12541) N
UXP-060	(t + 0.141732) N	(t + 0.133858) N	GXD-085, -145, -205, -265, -325	(t + 0.13441) N	(t + 0.12541) N
UXP-400	(t + 0.141732) N	(t + 0.133858) N	GFP-057, -097, -187	(t + 0.2965) N	(t + 0.3025) N
UXP-110	(t + 0.141732) N	(t + 0.133858) N	GCP-010	(t + 0.1378) N	(t + 0.1299) N
SXP-070, SXP-400, SXP-140	(t + 0.102362) N	(t + 0.094488) N	GCP-016	(t + 0.07205) N	(t + 0.06969) N
UXP-801	(t + 0.181102) N	(t + 0.173228) N	GCP-026	(t + 0.1633) N	(t + 0.1523) N
UXP-802	(t + 0.181102) N	(t + 0.173228) N	GCP-051	(t + 0.1601) N	(t + 0.1548) N
GFP-030	(0.1881N) + 0.07874	(0.1767N) + 0.07874	GCP-060	(t + 0.1790) N	(t + 0.1676) N
GFP-080	(0.189013N) + 0.07874	(0.1796N) + 0.07874	GCD-012	(t + 0.1000) N	(t + 0.09685) N
GXD-007	(t + 0.10191) N	(t + 0.09491) N	GLD-230, -330, -430	(t + 0.1831) N	(t + 0.1713) N
GXD-012, GXD-018, GL-013	(t + 0.11821) N	(t + 0.11021) N			

\*Applicable to units with elastomeric gaskets, round off to the nearest 1/32 in. Units with teflon encapsulated gaskets should be tightened to the “A Max.” formula.

The single digit of the model number given just before the frame designation indicates the plate thickness in tenths of a millimeter. The only exception is the zero (0) designation, which indicates a 1.0 mm plate thickness.

### HOW TO USE TABLE 3:

EXAMPLE: Given a model UXP-100-L-6-MP-32, go to the Plate Pack Width chart above and select Plate Designation 6, the Plate Designation for a model UXP-100. The corresponding Plate Thickness is 0.023622 in. Now find the Plate Type row showing UXP-100 in Table 3. The “A Max.” dimension is calculated by: (t+0.0944)N = (0.023622+0.0944)32 = 3.78 in. The “A Min.” dimension is calculated in a similar manner. Round off calculated number to nearest 1/32 in.

## Plate Designations

SUPERCHANGER units are designed so that a fluid which enters the “A” plate circuit (nozzles S1, S2, M1 or M2) always flows in the “A” circuit only. Fluid which enters the “B” plate circuit (nozzles S3, S4, M3 or M4) always flows in the “B” circuit only. Facing the stationary frame, the right side is always the “A” side, while the left side is always the “B” side. The “A” and “B” term refers to the gasket orientation. When looking at the gasketed side of the plate, an “A” plate becomes a “B” plate when reversed (turned upside down). If the flow comes in and out on the left side, it is a “B” orientation.

**NOTE:** Every other plate has to be rotated 180° A-B-A-B in order to prevent mixing. The first plate in the unit is called a “D” plate and has a special gasket arrangement. This arrangement keeps the flow from contacting the stationary frame. The last is called the “E” plate and is gasketed normally.

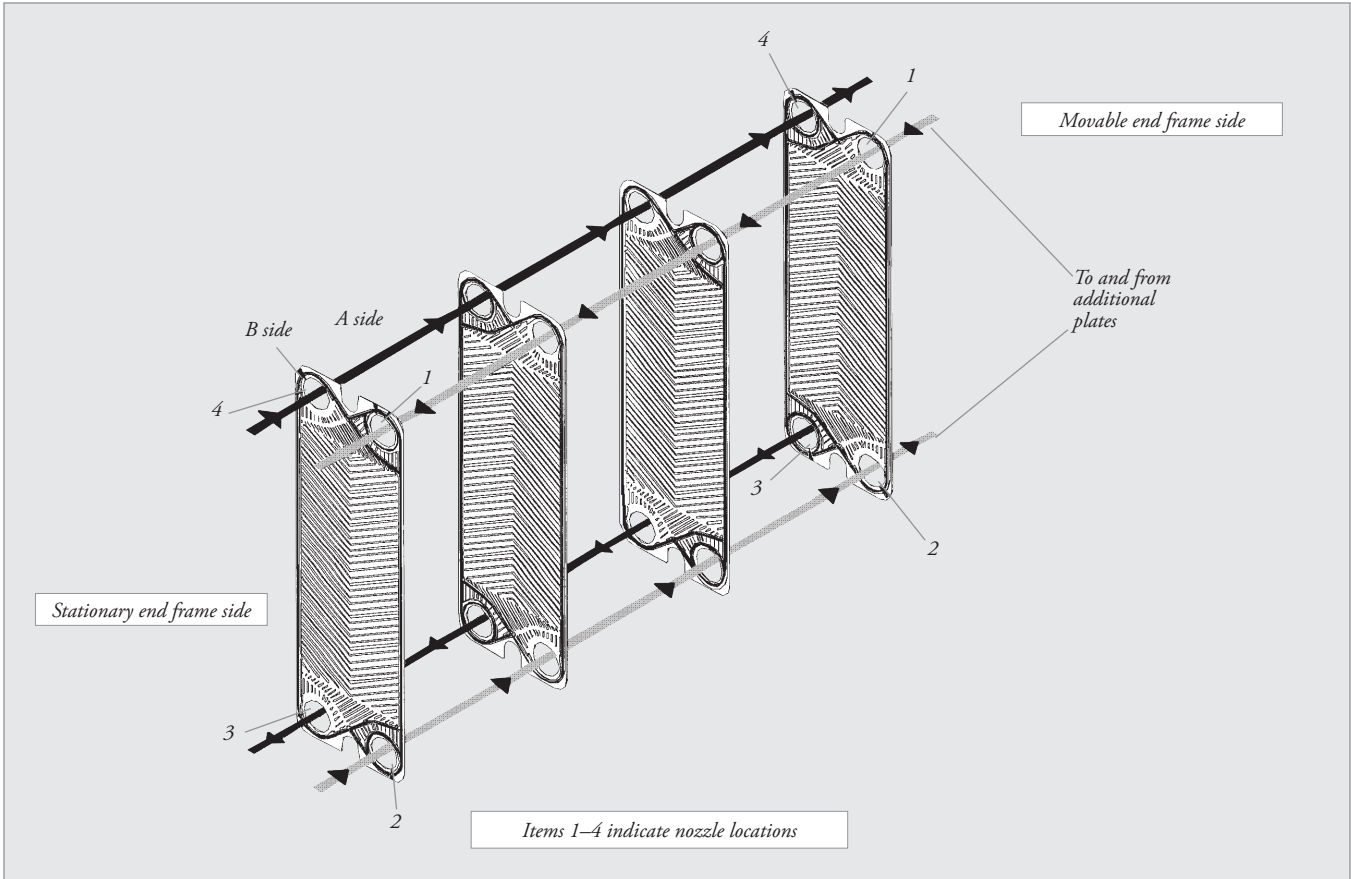

Figure 11  
Plate orientation for the UX, SX, GC and GF Series.

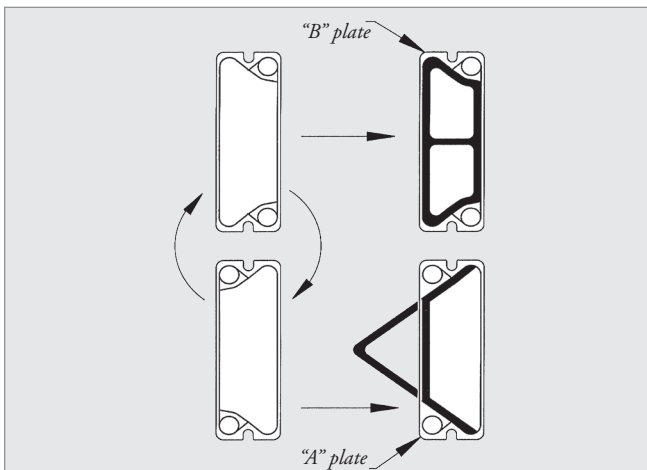

Figure 12  
Gasket orientation.

## Drawings

SUPERCHANGER units are custom designed for each application. A drawing is supplied with each unit depicting all required dimensional data, equipment specifications, unit performance, nozzle locations and sequence of plates in the heat exchanger. Most information contained on the drawing is self-explanatory. However, sections illustrating the internal functions of a plate and frame heat exchanger are sometimes difficult to interpret. The following diagrams are aids for understanding the equipment.

### Element Composition Diagram

Figure 13 shows an “S” frame (stationary member), “E” frame (moveable member) and plates of the plate heat exchanger depicted in an element composition diagram. In an element composition diagram, “B” plates are located at the upper part of the drawing and “A” plates are shown on the lower side.

A plate is indicated by the line centrally located within a rectangular compartment between the “S” and “E” frames.

The designation of plate holes is written in the hole designation box formed by extending the vertical plate lines above the center line for “B” plates and below the center line for “A” plates. The plate sequence number is written in a box above and below the plate hole number, respectively, for “B” and “A” plates.

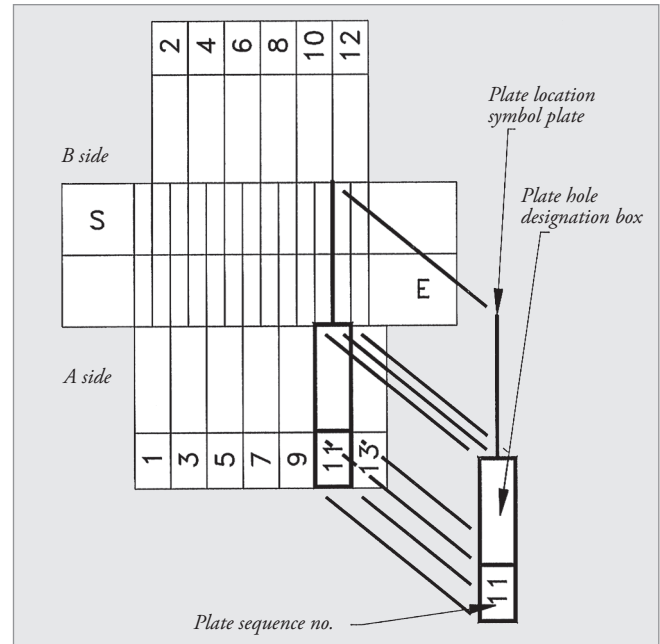

Figure 13  
Element composition diagram.

## Plate Hole Designation for UX, SX, GC and GF Series

As shown in Figure 14, the pierced holes at the corners of the plate are designated as: 1 for upper right, 2 for lower right, 3 for lower left and 4 for upper left when facing the gasketed side of the plate. Plates 1 and 2 in Figure 14 are represented as A1234 and B1234 respectively. Plates with all four holes pierced can also be designated with a blank space or an \*. Unpierced ports will be represented as a zero (0). For example, Plate 3 is represented by a A1004 since there are no holes at position 2 and 3. Table 8 shows **A and B equivalents when an “A” plate is rotated to become a “B” plate.**

Make sure the gaskets are installed correctly in relation to the flow directors. (See Figures 15 and 16.)

"A" Plate	"B" Plate	"A" Plate	"B" Plate
1234	1234	0204	0204
1034	1230	0034	1200
1204	0234	1200	0034
0234	1204	0004	0200
1230	1034	1000	0030
1004	0230	0030	1000
0230	1004	0200	0004
1030	1030	0000	0000

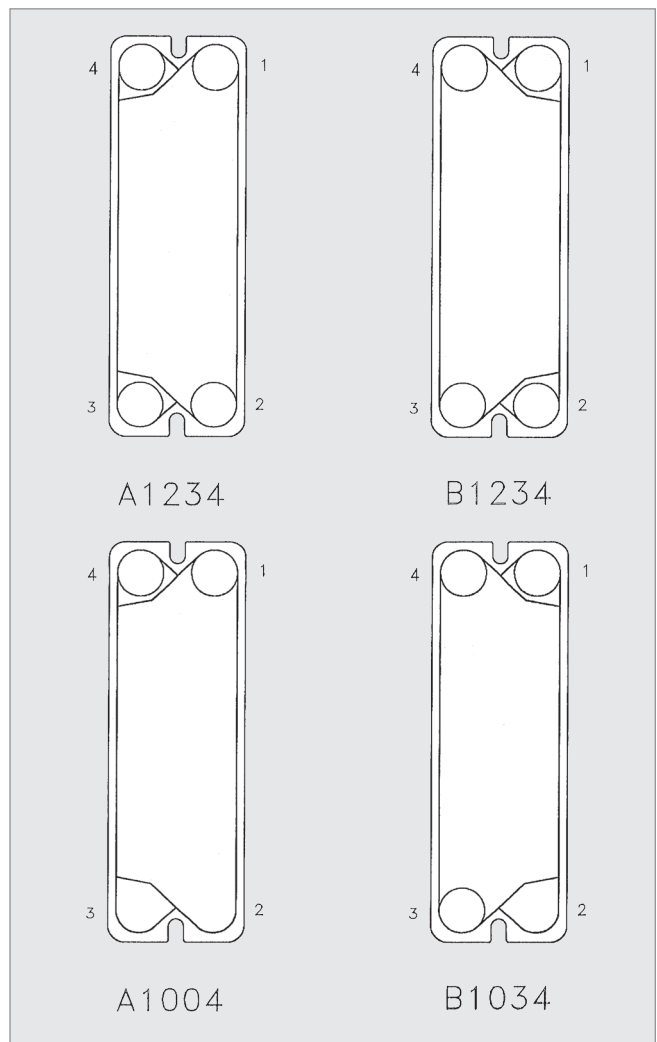

Figure 14  
Hole designations.

Porthole designations shown apply to all units purchased after June 1, 2002. Refer to unit drawing or previous IOM (SC-10M-9) for older UX, SX, S, GF or TW Series.

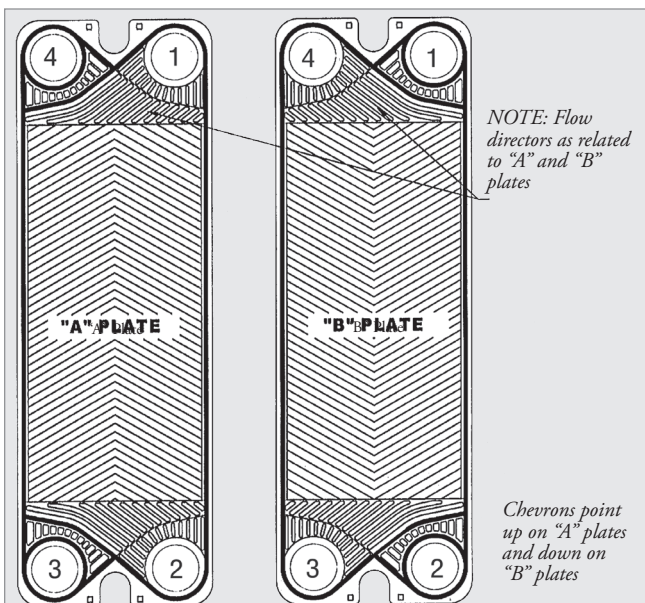

Figure 15  
Correct gasket location.

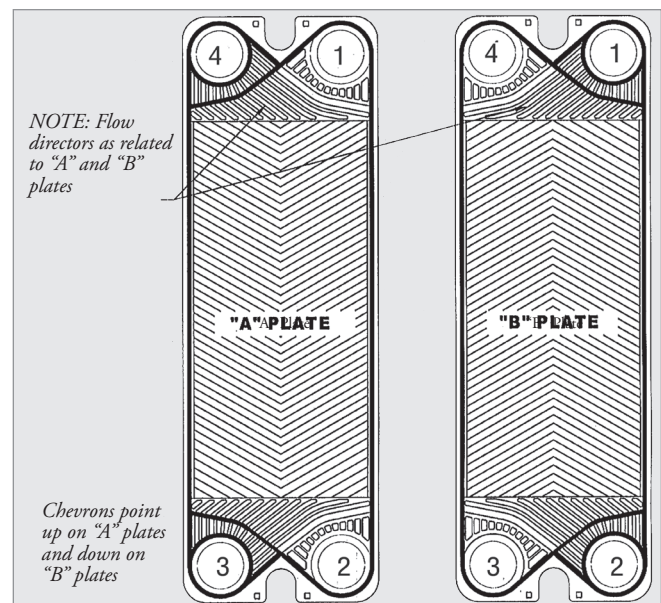

Figure 16  
Incorrect gasket location.



# PASS AND FLOW ARRANGEMENT

## Pass Arrangement

Positions 1 and 4, as shown above in Figure 17, are upper connections, right and left respectively, and positions 2 and 3 are lower connections, right and left respectively. Each vertical line in between the “S” and “E” members represents a heat transfer plate while the arrows show the directions of flow in the channels between two plates and in the port holes.

The position of a plate hole is indicated by the intersection between a vertical line representing the plate and a horizontal line indicating the flow direction and passage. Holes for passage of fluid flowing on the surface of a “B” plate are always located on the left side (Holes 3 and 4), and holes for passage of liquid flowing on the surface of an “A” plate are always found on the right side (Holes 1 and 2).

In the element composition diagram (Figure 17), plate numbers are shown in boxes as:

1	D1004
---	-------

 (“A” side)

1034	2
------	---

 (“B” side”)

“D” in D1004 represents the plate adjacent to the “S” frame. “D” also denotes that no fluid runs on the heating surface.

A box with no port hole numbers, 

11	
----	--

, in Figure 17 means 

11	1234
----	------

. This is done for simplicity as most plates in a unit have four holes.

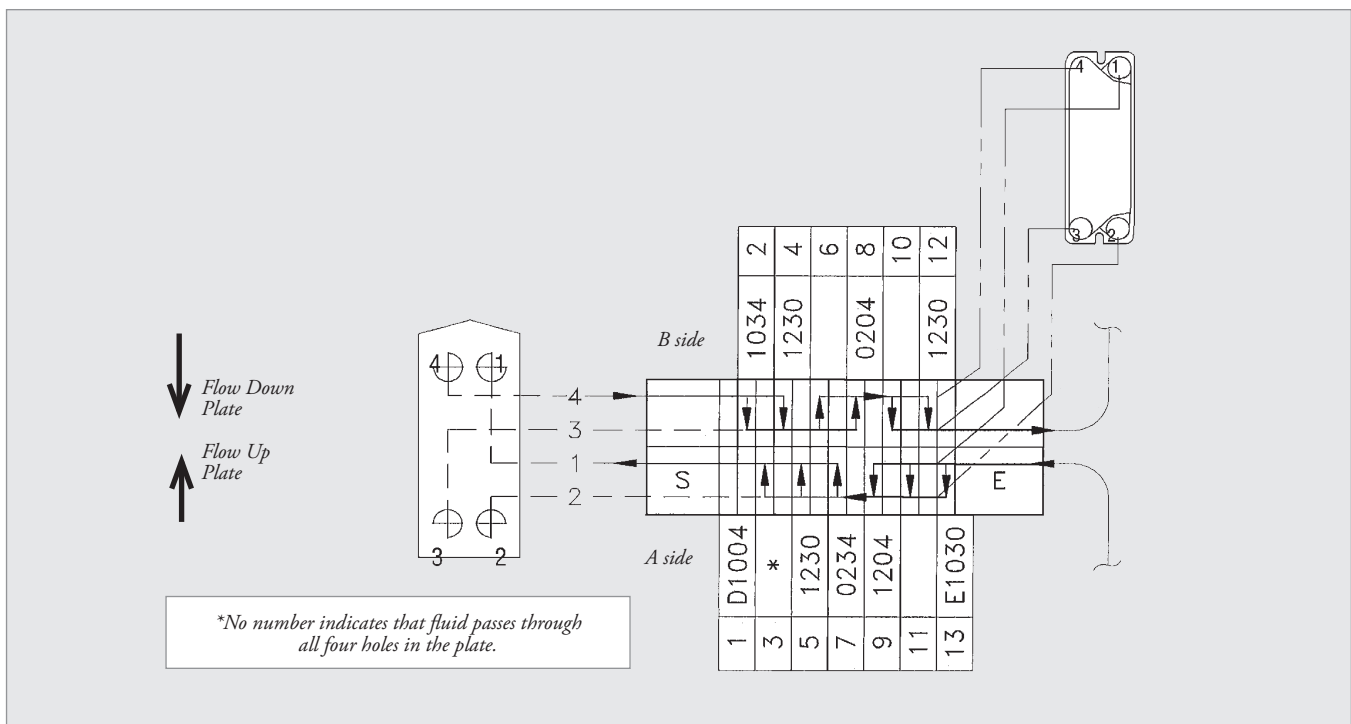

Figure 17  
Element composition diagram.

## Flow Arrangement

Figure 18 shows the plate arrangement in which “B” side is arranged in two parallel channels with three passes in series and “A” side is arranged in three parallel channels with two passes in series. In two parallel channels with three passes in series, the fluid flow  $Q_1$  flows on the heating surfaces of two plates separately ( $Q_1/2$ ) and gathers again in the port hole. This operation is repeated three times. In the case of three parallel channels, with two passes in series, flow  $Q_2$  similarly flows on the three heating surfaces separately ( $Q_2/3$ ), gathering once again in the port hole.

number of passes in series, is always equal or different from each other by one plate when comparing “A” side with “B” side. The total number of plates can be obtained by adding the number of “D” plates to the number gained by adding the products of “A” side and “B” side. In Figure 18  $(2 \times 3) + (3 \times 2) + 1 = 13$ .

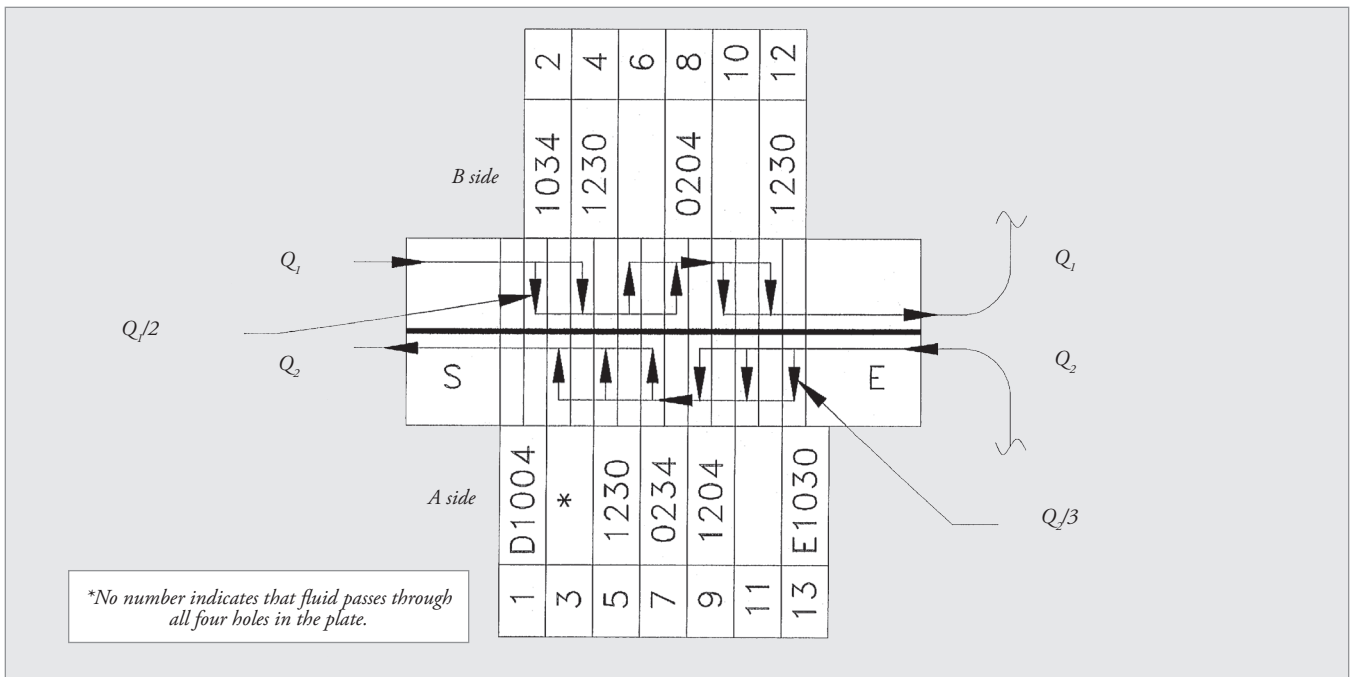

Figure 18  
Flow arrangement.

## Drains

There are three methods used for draining SUPERCHANGER units:

1. One pass/one pass (also two pass/two pass with all lower nozzles, but not shown) units can be drained by opening the piping to the lower nozzles or by opening drain valves that can be provided in the field in the connecting piping. See Figure 19.
2. Multi-pass units may require factory installed drains, i.e., an additional nozzle in the end frame. **These must be factory installed. See Figure 19.**
3. If the number of passes is greater than four as in Figure 20, the above options require the addition of small holes in plate corner sections as shown in Figure 22. The amount of by-pass through these holes is negligible and there is no possibility of fluid intermix. These drain holes in the element composition diagram (Figure 21) are noted by ●, as the small hole is always placed in the corner without a passage hole. For example, 1204 is changed to 12●4 if a drain hole is present. The size and position of the drain hole is separately specified.

**NOTE:** On multi-pass units that are sized for a close temperature approach, these drain holes are not provided due to the small amount of bypassing that occurs. Check the drawing to determine whether drains are present.

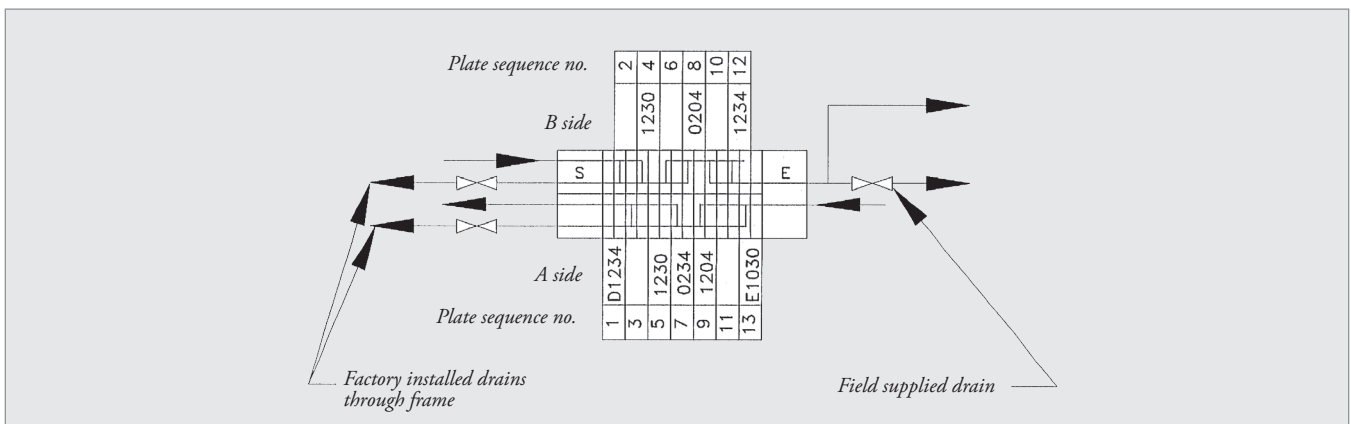

Figure 19  
One pass—one pass.

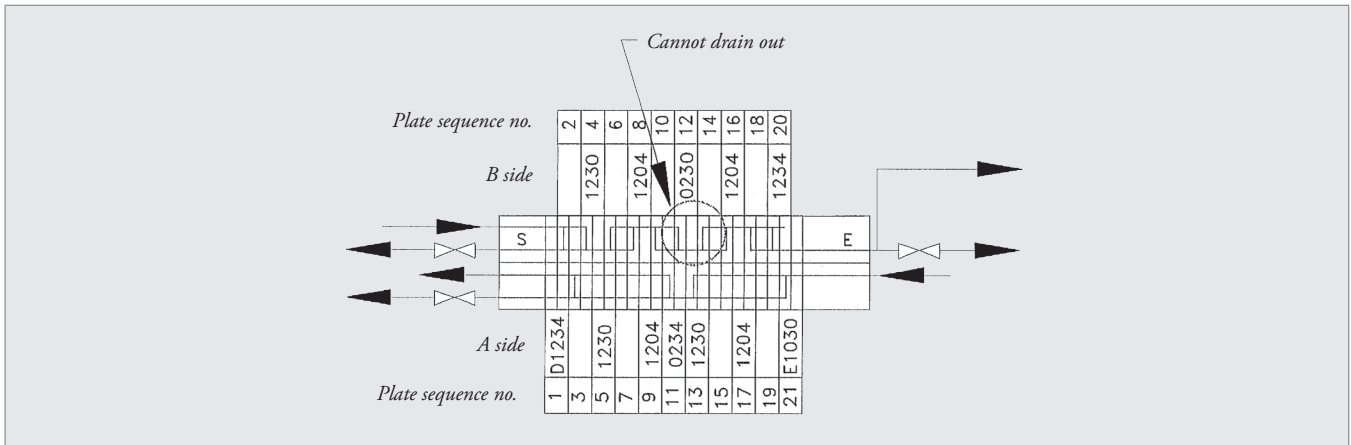

Figure 20  
Five-pass unit with 2 passes that are not drainable.

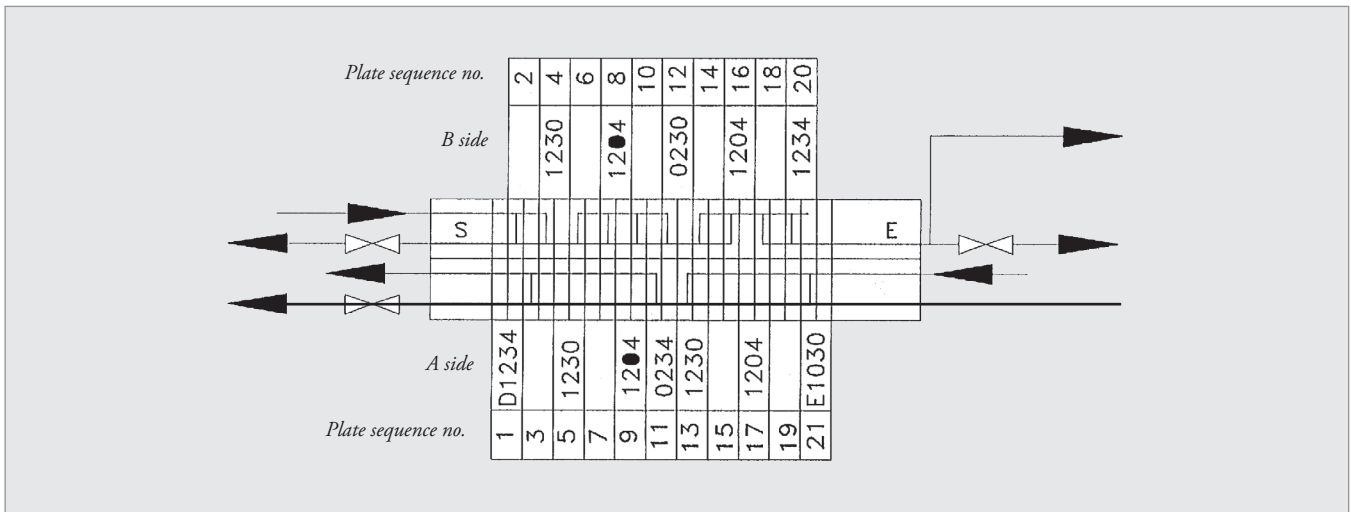

Figure 21  
Five-pass with pass 3 and 4 as drainable. (Plates 8 and 9 have small drain holes.)

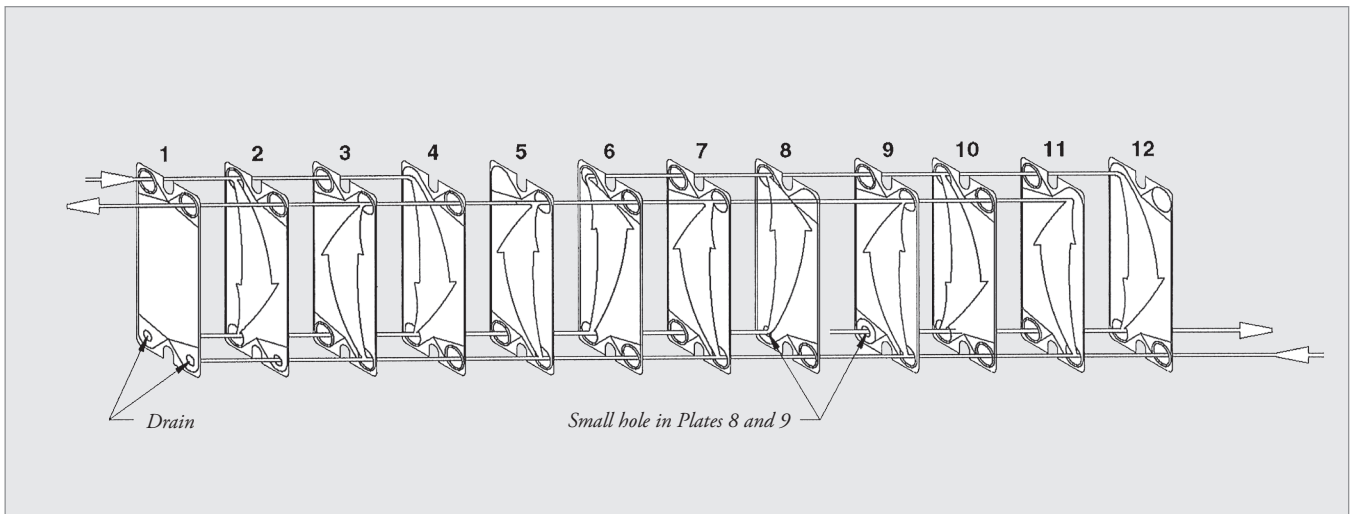

Figure 22  
Showing first 12 of the 21 plates in Figure 21 with drains in plates 8 and 9.

## Connecting "C" Frames

SUPERCHANGER units can be partitioned into multiple sections by employing the required number of connecting "C" frames when more than one heat exchange operation is required. Connecting frames allow several liquids to be processed at the same time or allow the same liquid to run through several stages of heat transfer. The flow arrangement with use of a connecting frame is illustrated in Figure 23 isometrically and in Figure 24 in an element composition diagram.

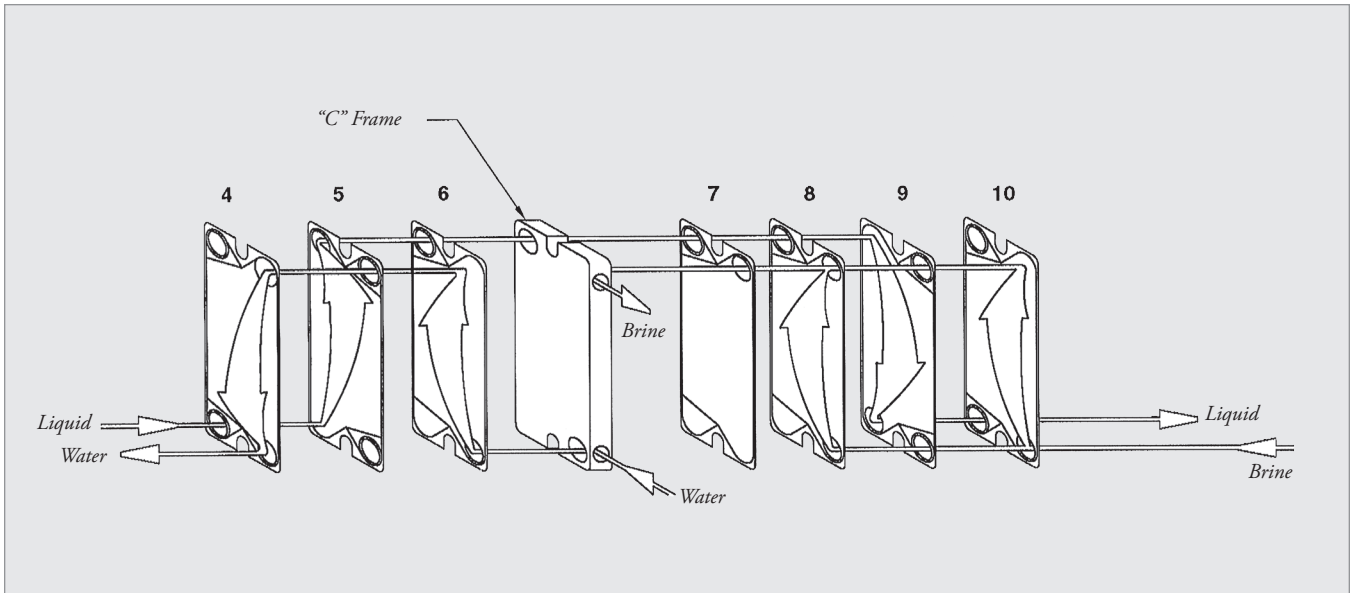

Figure 23  
Connecting "C" frame—flow diagram.

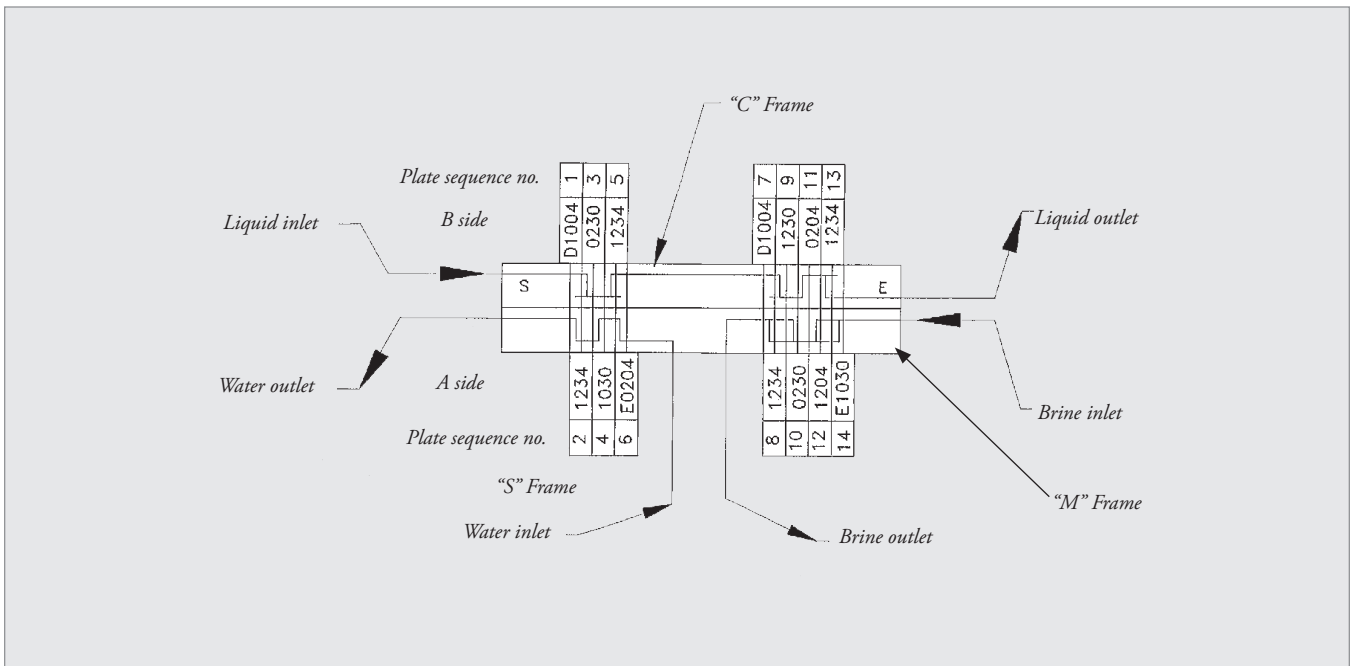

Figure 24  
Connecting "C" frame—element composition diagram.

## PLATE STYLES

Unlike all other SUPERCHANGER models, the GX series of plates is based on a diagonal flow pattern. On a typical one-by-one pass unit, nozzle numbers 1 and 3 will be the hot inlet and hot outlet connections. Nozzle numbers 2 and 4 are the cold inlet and cold outlet located lower right and upper left, respectively. Unlike other plates, GX series can also be designed for parallel flow. The flow direction is always designated in the model number by a “P” (parallel) or “D” (diagonal) after the letters “GX.”

ULTRAFLEX (GX) and WIDE-GAP (GF) plates differ from conventional plates in another aspect. Because the gasket groove lies in the plate’s neutral plane, additional configurations are possible with a given plate. This feature allows the heat exchanger to be more precisely designed for each application.

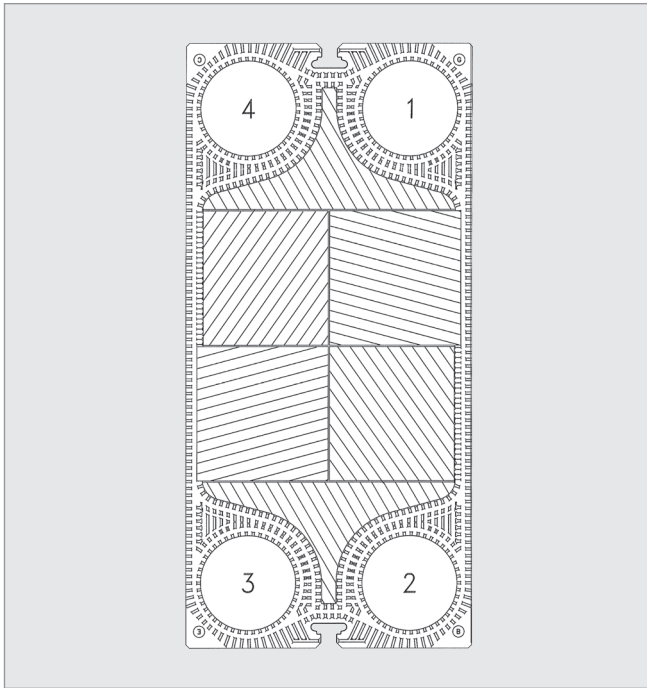

Figure 25  
*ULTRAFLEX (GX) plate design.*

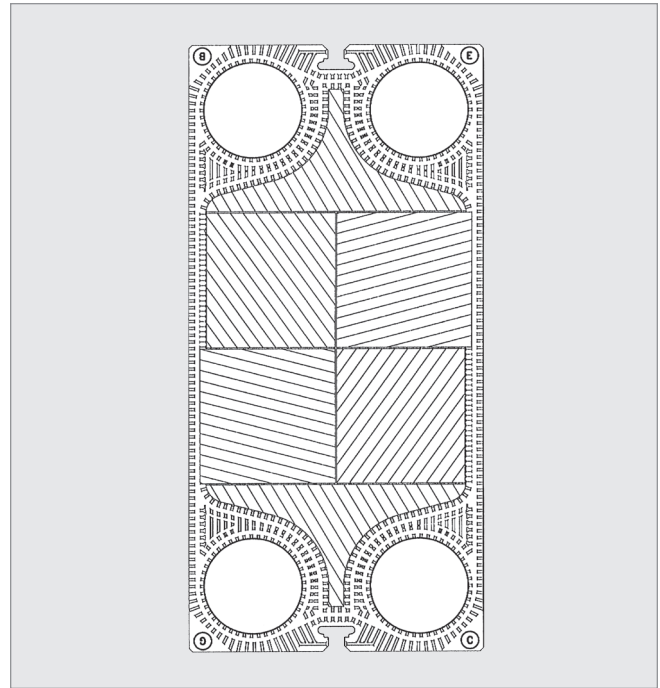

Figure 26  
*GX type “H” plate.*

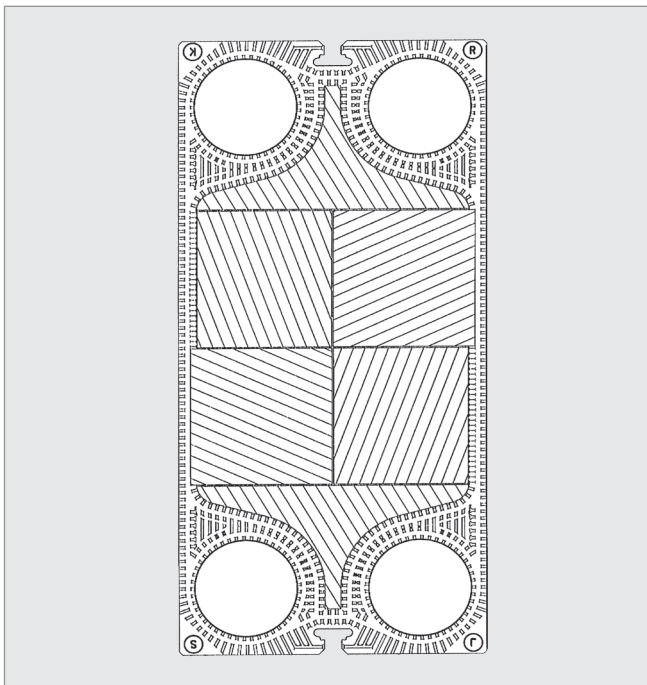

Figure 27  
*GX type “L” plate.*

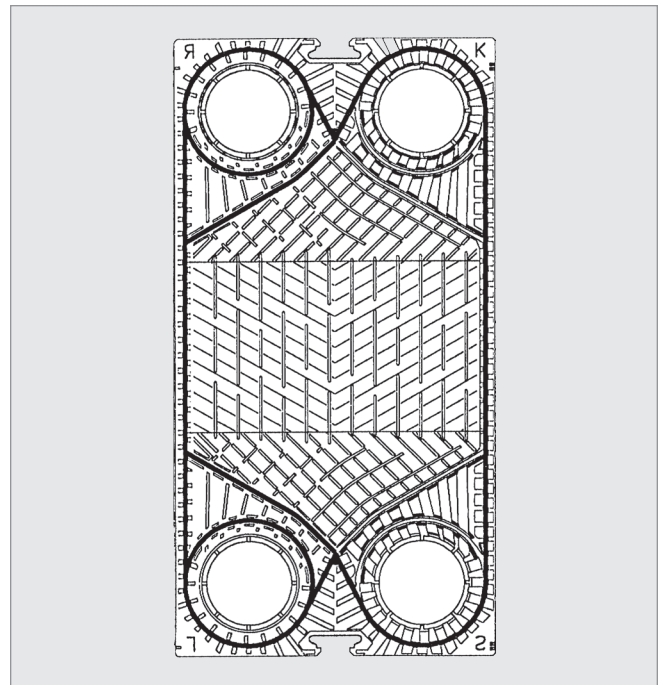

Figure 28  
*GF-type plate.*



## Drawings

The bottom left hand corner of each GF and GX unit drawing has a plate specification chart and plate arrangement/assembly listing to assist in determining the proper sequence and orientation of the plates in the unit. You will note that the gaskets used between the first and last plate of the plate pack and the respective frames are half thickness.

Due to the number of combinations achievable with GX and GF technology, we have simplified the assembly process by assigning a code letter to each corner of the plate. The plate is installed correctly when the letter is readable from the upper right corner when facing the front of the unit.

The following examples will help you understand the plate designations:

Quantity	Gasket Material	Theta/Piercing	Gluing
1	NBR	H 1234	RC Start
134	NBR	H 1234	LG
133	NBR	H 1234	RC
1	NBR	H 0000	RC End

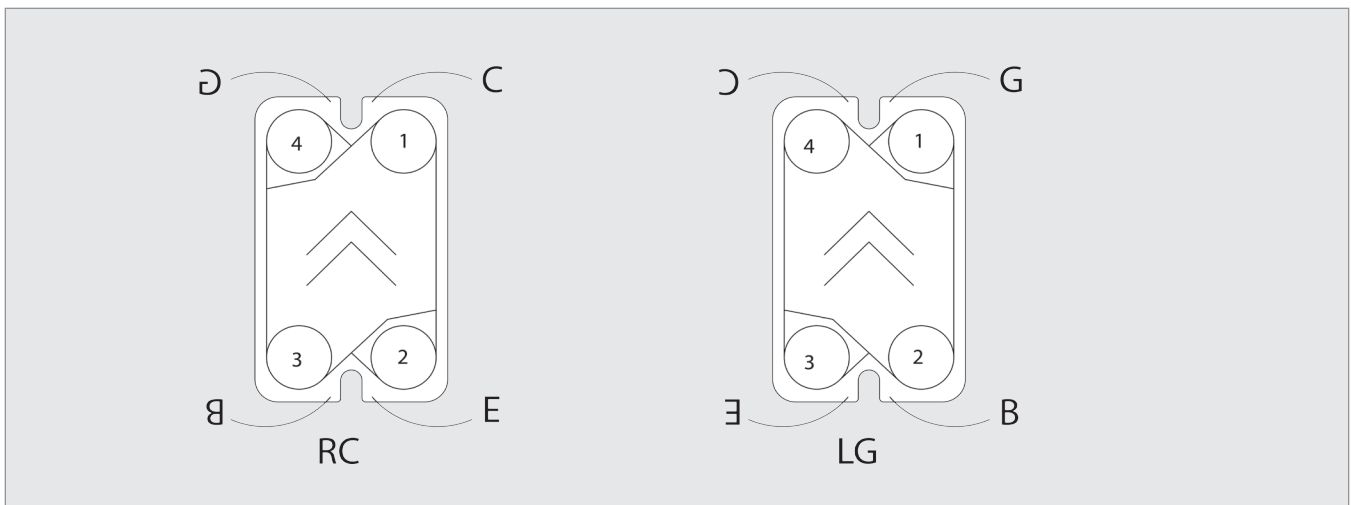

Figure 29  
Ultraflex plate gluing assembly.

## WIDE-GAP PLATE ASSEMBLY

In the Wide-Gap (GF) series of plates, three different channel geometries can be created with each model: wide, medium or narrow. All units will be wide-narrow, narrow-wide or medium-medium configuration. The code letter in the top right hand corner of the plates is used to create the various channel geometries as shown below.

GAP	FLOW ON SIDE	CODE
Wide	A	R + L
Wide	B	S + K
Medium	A	K + L or R + S
Medium	B	L + K or S + R
Narrow	A	K + S
Narrow	B	L + R

## Four-Plate Sequence

In some instances, the arrangement in a GX model will follow a repeating four-plate sequence. An example is shown below:

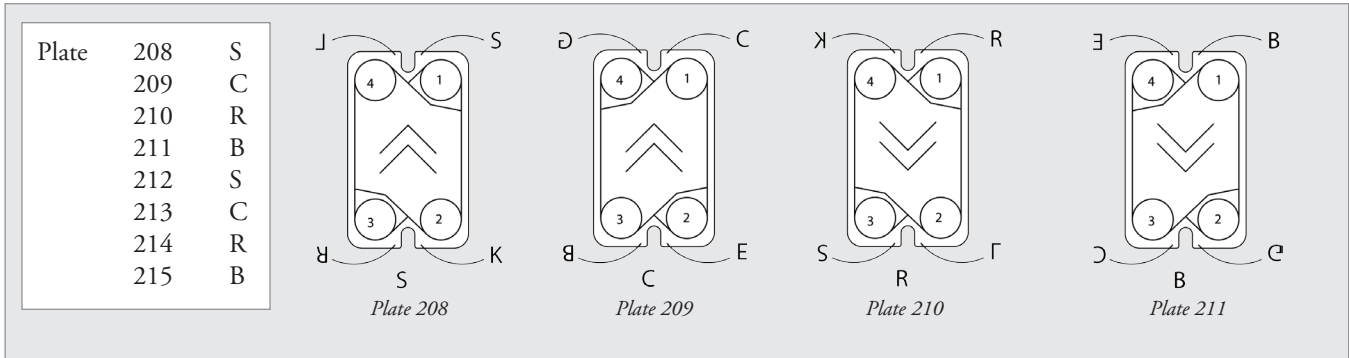

Figure 30  
Four-plate ULTRAFLEX sequence.

Table 5 Plate Hanging Assembly—Four-Plate Sequence

Plate Sequence	Gasket Material	Piercing	Gluing	Hanging
1	NBR	H 1234	RC Start	B
2, 4....206	NBR	L 1234	LS	R
3, 5....207	NBR	H 1234	RC	B
208, 210....266	NBR	L 1234	LS	S, R
209, 211....267	NBR	H 1234	RC	C, B
268	NBR	L 1234	LS	S
269	NBR	H 0000	RC End	C

## Multi-Pass Units

Table 6 provides an example of plate arrangement and specifications for a multi-pass unit.

Table 6 Plate Hanging Assembly—Multi-Pass Units

Plate Sequence	Gasket Material	Piercing	Gluing	Hanging
1	NBR	H 0234	RC Start	B
2, 4....22	NBR	L 1234	LS	R
3, 5....23	NBR	H 1234	RC	B
24	NBR	L 1234	LS	R
25	NBR	H 1004	RC	B
26, 28....46	NBR	L 1234	LS	R
27, 29....47	NBR	H 1234	RC	B
48	NBR	L 1234	LS	R
49	NBR	H 0230	RC End	B

# GASKET DATA

**Table 7** Temperature Ratings

Gasket Material	Max. Temp. (°F)	Color Code
EPDM (Full FDA Approved)	300	1 Grey + 1 Red
EPDM (Industrial Grade)	338	1 Grey
EPDM (Partial FDA Approved)	338	3 Grey
EPDM(IR)	338	1 Grey + 1Green
EPDM(P) Soft	338	2 Grey + 1 Green
EPDM(S)	338	2 Grey
EPDM-XH	338	4 Grey
Fluoroelastomer (Viton) A & G	350	1 Purple
Fluoroelastomer (Viton) B	350	2 Purple
Fluoroelastomer (Viton) FDA Full	356	1 Purple + 1 Red
Fluoroelastomer (Viton) GF	350	3 Purple
Fluoroelastomer (Viton) GF 04-312	356	1 Purple + 1 White
Steam grade fluoroelastomer for GE test units	266	4 Purple
Hypalon (CSM)	158	1 Red
NBR (Full FDA Approved)	270	1 Blue + 1 Red
NBR (Hydrogenated)	302	2 Blue
Gasket Material	Max. Temp. (°F)	Color Code

NBR (Industrial Grade)	270	3 Blue
NBR (Partial FDA Approved)	270	1 Blue
NBR LH (Low Hard)	284	1 Blue + 1 Green
NBR LT (Low Temp)	284	1 Blue + 1 Yellow
NBR(P)	284	1 Blue or (1 Blue + 1 White)
NBR(S)	284	No marking
NBR(S) 14-920	284	1 Blue + 1 Brown
Neoprene (CR)	255	1 Green
PTFE encapsulated EPDM	338	Nothing on the outside (core EPDM is marked with 1 Grey)
PTFE encapsulated NBR	270	Nothing on the outside (core NBR is marked with 3 Blue)
R.C. Butyl	230	1 Yellow
Silastic (Dow)		None
Silicone		1 Orange (only if the rubber color is black)

\*This gasket requires the use of .8 mm (.032 in.) thick plate and a special double side tape instead of Pliobond.

**DO NOT OVER TIGHTEN!**

The above temperatures are the maximum allowable temperature. In some cases, the upper limit may be lower depending on the fluids being handled and on the unit design pressure.

## Gaskets—Glued

Each plate has a molded one piece boundary gasket which is glued into the continuous gasket groove in each plate. The liquid flowing on the surface of each plate flows on the inside of each boundary gasket.

Every port hole gasket contains four bleed passages. (See Figure 32.) If one of the liquids should leak beyond a boundary gasket, it will flow to the outside of the unit, thus preventing any possible intermix. (See Figures 31 and 33.)

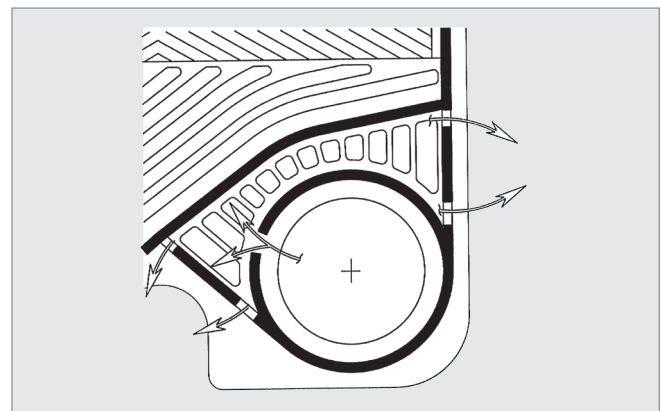

**Figure 31**  
Flow to exterior from damaged boundary gasket.

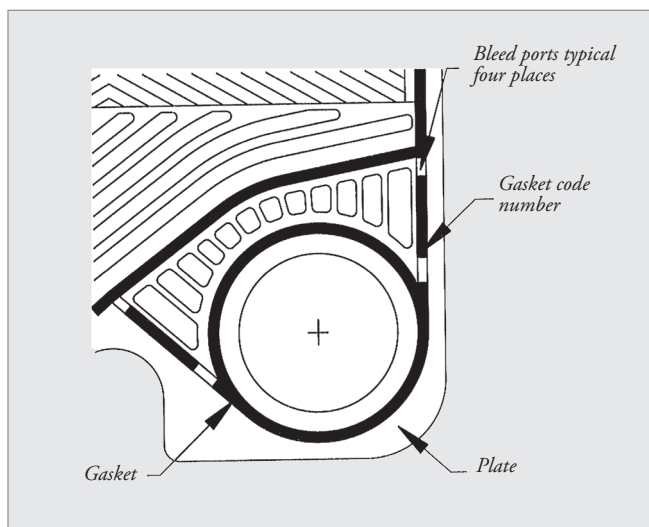

**Figure 32**  
Four bleed passages.

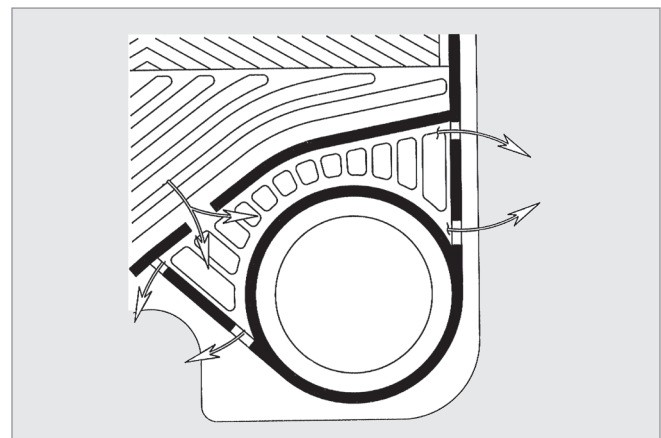

**Figure 33**  
Flow to exterior from damaged boundary gasket.

## Gaskets—Glueless

### SUPERLOCK®

Functionally, Tranter’s patented SUPERLOCK® glueless gaskets perform in the same manner as glued gaskets (see Figures 30, 31 and 32). SUPERLOCK’s unique lock-in design allows simple installation and removal without glue. The gasket has tabs that press easily into the holes in the plate. Please note that the differences between glueless gasket plate assemblies and glued gasket plate assemblies do not allow for the use of a glued gasket on a SUPERLOCK style plate. The use of a glueless gasket on a plate requiring a glued gasket is also incorrect. (NOTE: the D, E and any special turning plates will be standard spot-glued gasketed.) The SUPERLOCK design is indicated by replacing the “X” in the model number with an “M” for a mechanically attached gasket. It is available in the following models: UMP-005, UMP-010, UMP-060, UMP-200, UMP-400, GMP-026 and GM-010.

### Clip-On

Tranter’s Clip-On glueless gaskets also perform in the same manner as glued gaskets. The unique design allows easy and fast clip-on installation without glue or tools, as well as simple removal. Positive gasket seating and lock-in eliminates assembly uncertainties. After inspection, undamaged gaskets can be reused.

The Clip-On gasket system is available in NBR and EPDM, both industrial and FDA ratings. The Clip-On design is available in the following models: GMP-026, GC-8, GC-026, GX-26, GX-42 and GL-13. Four of these models—GC-8, GX-26, GX-42 and GL-13—are interchangeable plates, and can be used with either glued or Clip-On gaskets.

**Table 8** Typical Clip-On Gasket Installation

PLATE NO.	GASKET	PLATE	CLIPPING	HANGING
1	NBR (S)	H0230	RC START	B
2, 4, 6, 8, 10	NBR (S)	H1234	LG	E
3, 5, 7, 9, 11	NBR (S)	H1234	RC	B
12, 14, 16, 18	NBR (S)	H1234	LG	GE
13, 15, 17, 19	NBR (S)	H1234	RC	CB
20	NBR (S)	H1234	LG	G
21	NBR (S)	H1004	RC END	C
22	NBR (S)	H1004		PARTITION
23	NBR (S)	H1004	RC START	B
24, 26, 28, 30, 32	NBR (S)	H1234	LG	E
25, 27, 29, 31, 33	NBR (S)	H1234	RC	B
34, 36, 38, 40	NBR (S)	H1234	LG	GE
35, 37, 39, 41	NBR (S)	H1234	RC	CB
42	NBR (S)	H1234	LG	G
43	NBR (S)	H0230	RC END	C

Model: GXD-042; Plate Material: 304 SS; Plate Thickness: 0.5 mm.

**Plate No.:** Indicates plate number if single number is given. Indicates a numerical sequence pattern if multiple numbers are given. If multiple letter codes are given in the Hanging column, an alternating sequence between the two letters should be followed as indicated in the Plate No. column.

**Gasket:** Defines the gasket material.

**Plate:** A five-digit identifier, which describes plate theta as being “H” high or “L” low, is followed by four integers. These four integers indicate which ports are pierced. A zero (0) denotes NO piercing at this port location.

**Clipping:** An eight-character field describing how the gasket is to be clipped to the plate. The first letter describes whether the closed port (ringed gasket corner) is in the Lower Right or Lower

Left. Therefore, “R” is Right and “L” is Left. The second letter denotes the plate letter code. Both of these descriptions apply when the plate is viewed upright with the designated letter code being read left-to-right in the upper right hand quadrant of the plate. Gaskets will be clipped to the front of plate as viewed in their installed orientation from front-to-back of the assembled unit. “Start” or “End” can be added to the first two-letters with a space between to denote special gasketing instructions for the first and last plates between end-frames and/or partition plates.

**Hanging:** Indicates the letter code by which a plate is to be hung in the unit. This letter should be located in the upper right of the plate and read from left-to-right. The plate should be viewed as if from looking from the front of the unit.

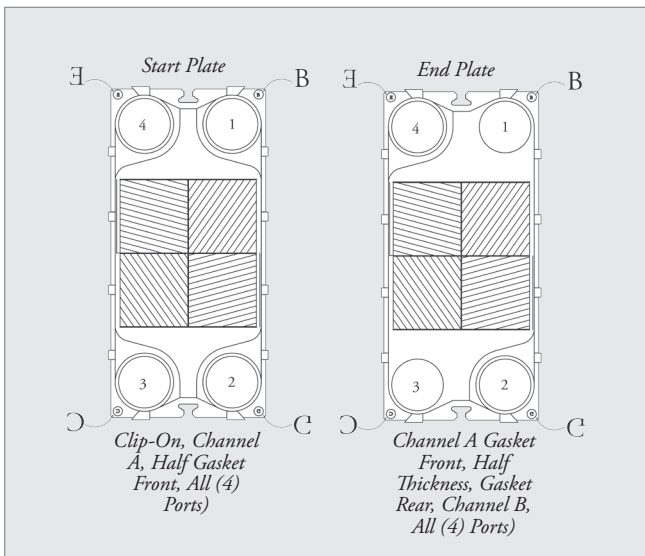

Figure 34  
GX Clip-On codes (diagonal flow).

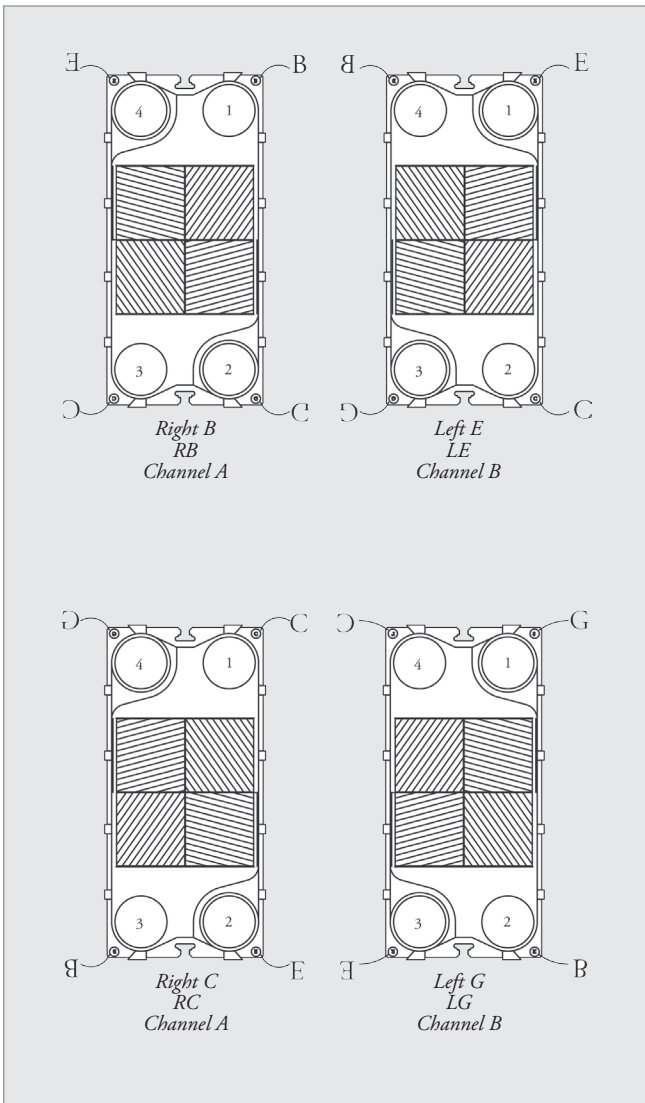

Figure 35  
GX Start and End plate explanations.

## Gasket Storage Procedures

When SUPERCHANGER heat exchanger plate gaskets are maintained as spare parts, it is important that certain storage procedures be followed to assure that the elastomeric compounds making up the gaskets do not deteriorate and the useful life of the gaskets is preserved.

1. Store in an area where the temperature does not exceed 70°F. The ideal storage temperature is 60°F. NOTE: Never store in an area where the temperature may fall to or below 32°F.
2. Maintain a maximum of 70% relative humidity.
3. Store in a darkened room. Ultraviolet light must be avoided.
4. Store gaskets so they are free from tension. Do not store in a stretched or severely bent condition.
5. All potential sources of Ozone, such as operating electric motors or welding equipment, must be removed from the storage area.
6. Organic solvents, acids, etc. must not be kept in the storage area.
7. Do not store near heating system radiators.
8. Cover or keep the gaskets in bags or boxes to minimize exposure to air circulation.
9. Keep gaskets free from dust and particulates.



## Mixed Gasket Materials

Most SUPERCHANGER units are equipped with gaskets made of one material. However, there are two conditions that dictate the use of different material on a plate.

The first is gasket/fluid compatibility. In this case, one material is not suitable for both fluids in the heat exchanger. An example is heating quench oil with 285°F steam. Quench oil dictates the use of nitrile rubber gaskets, while steam temperature requires EPDM gaskets.

The second reason for using two gasket materials on a single plate is cost. This is encountered when an expensive material (usually viton) is required on only one side of the SUPERCHANGER unit. A significant savings can be realized by using a less expensive gasket material on the other side.

As an example: Cooling 180°F sulfuric acid with tower water requires viton on the acid side, but nitrile is sufficient on the water side.

Each plate has contact with both fluids in a SUPERCHANGER

unit. One fluid travels across the plate while the other fluid passes through the gasketed port holes. In a mixed gasket unit, each plate will have two materials. The fluid traveling across the “A” plate requires gasket material 1. The fluid on the “B” plate requires gasket material 2.

In the case of a UX, SX, GF or GC series model, the “A” plate will have material 1 on the perimeter while port holes 3 and 4 are material 2. The “B” plate will have material 2 on the perimeter with port holes 1 and 2 of material 1. GX models with mixed gaskets would be similar. However, flow is diagonal so diagonally opposed ports would have the same gasket material.

All SUPERCHANGER gaskets are purchased as one piece-molded items. To physically accomplish mixing gaskets on a plate, the port holes are cut from both gaskets. Subsequently, the port holes of material 1 are matched with the perimeter of material 2 and vice versa. (See Figure 36.)

The following illustrates the above in a typical UX Series plate.

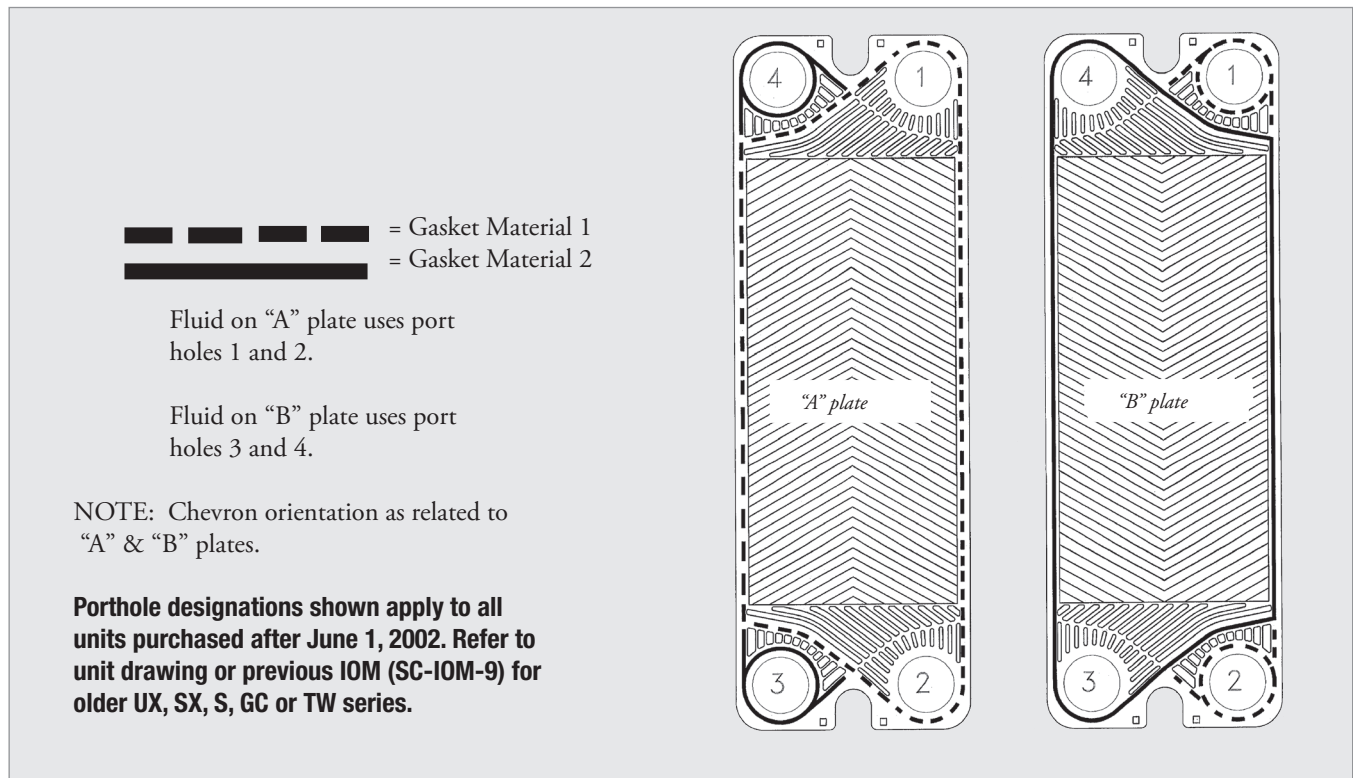

Figure 36  
Multiple gasket materials on a UX Series plate.

**Table 9** Typical Hanging Specification

PLATE NO.	GASKET	PLATE	GLUING	HANGING
1	NBR (S)	H0230	RC START	B
2, 4, 6, 8, 10	NBR (S)	H1234	LG	E
3, 5, 7, 9, 11	NBR (S)	H1234	RC	B
12, 14, 16, 18	NBR (S)	H1234	LG	G, E
13, 15, 17, 19	NBR (S)	H1234	RC	C, B
20	NBR (S)	H1234	LG	G
21	NBR (S)	H1004	RC END	C
22	—	H1004		PARTITION
23	NBR (S)	H1004	RC START	B
24, 26, 28, 30, 32	NBR (S)	H1234	LG	E
25, 27, 29, 31, 33	NBR (S)	H1234	RC	B
34, 36, 38, 40	NBR (S)	H1234	LG	G, E
35, 37, 39, 41	NBR (S)	H1234	RC	C, B
42	NBR (S)	H1234	LG	G
43	NBR (S)	H0230	RC END	C

Model: GXD-060; Plate Material: 304 SS; Plate Thickness: 0.5 mm.

**Plate No.:** Indicates plate number if single number is given. Indicates a numerical sequence pattern if multiple numbers are given. If multiple letter codes are given in the Hanging column, an alternating sequence between the two letters should be followed as indicated in the Plate No. column.

**Gasket:** Defines the gasket material.

**Plate:** A five-digit identifier, which describes plate theta as being “H” high or “L” low, is followed by four integers. These four integers indicate which ports are pierced. A zero (0) denotes NO piercing at this port location.

**Gluing:** An eight-character field describing how the gasket is to be glued to the plate. The first letter describes whether the closed port (ringed gasket corner) is in the Lower Right or Lower Left. Therefore, “R” is Right and “L” is Left. The second letter denotes the plate letter code. Both of these descriptions apply when the plate is viewed upright with the designated letter code being read left-to-right in the upper right hand quadrant of the plate. Gaskets will be glued to the front of plate as viewed in their installed orientation from front-to-back of the assembled unit. “Start” or “End” can be added to the first two-letters with a space between to denote special gasketing instructions for the first and last plates between end-frames and/or partition plates.

**Hanging:** Indicates the letter code by which a plate is to be hung in the unit. This letter should be located in the upper right of the plate and read from left-to-right. The plate should be viewed as if from looking from the front of the unit.

## GX Gluing Codes

### Diagonal Flow Plates:

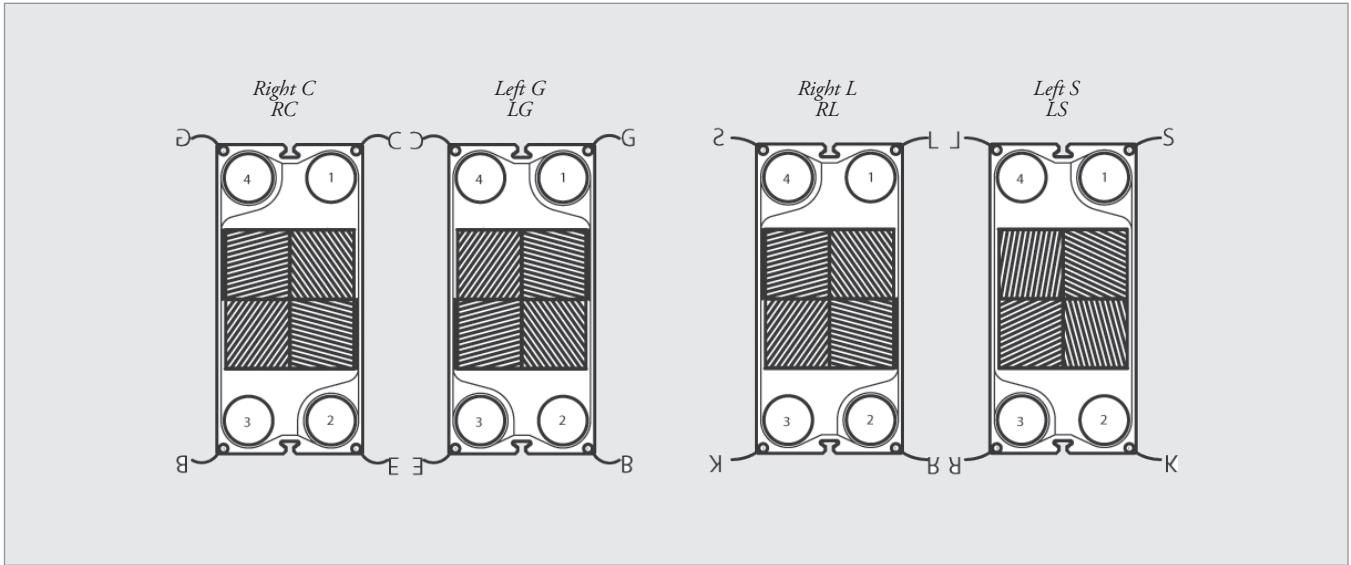

### Parallel Flow Plates:

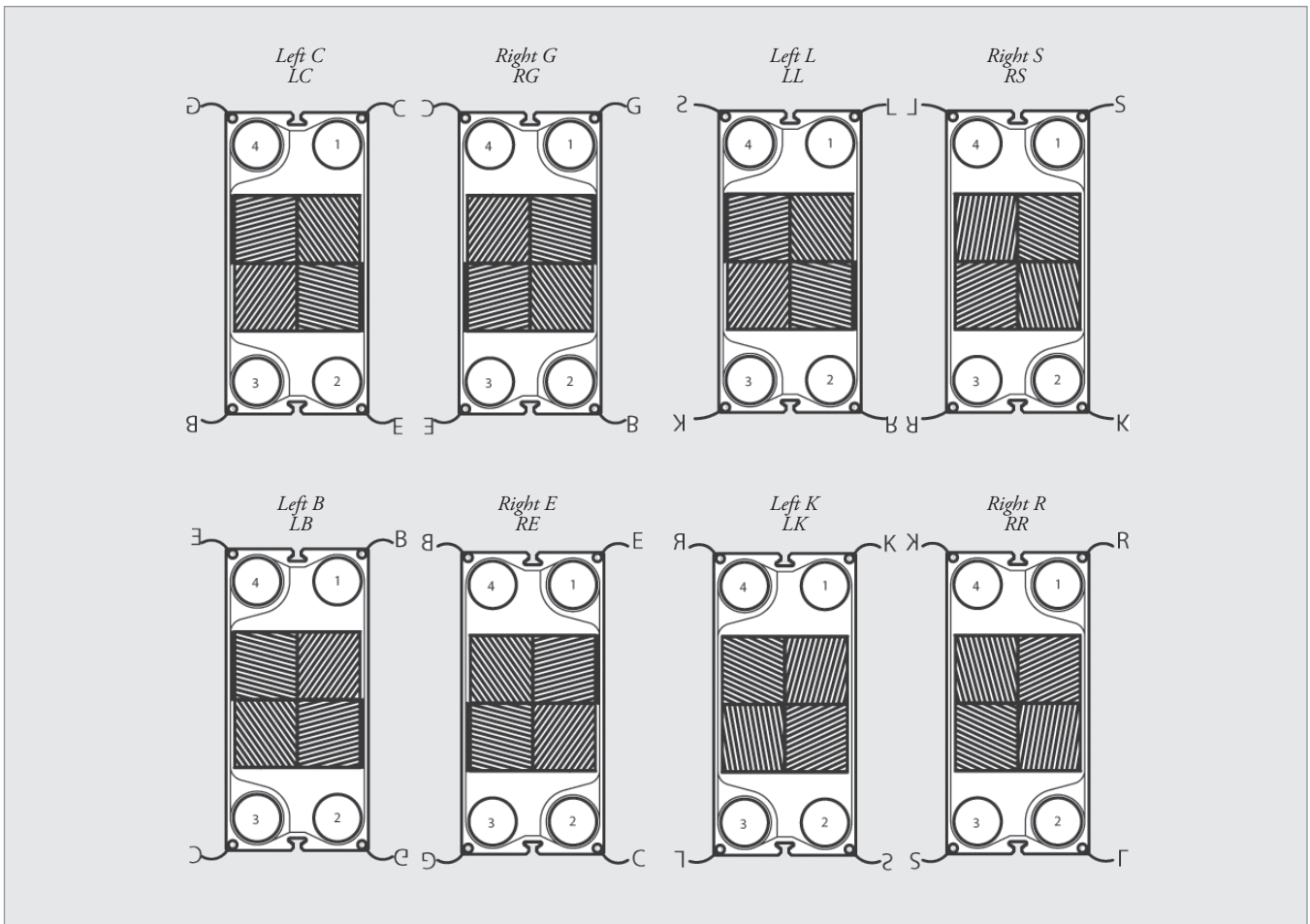

Figure 37  
 These drawings depict how GX plates are to be glued. Note that gluing instructions for diagonal flow GX plates can be reduced to four combinations while parallel flow GX plates require eight.

## GX Start and End Plate Explanations

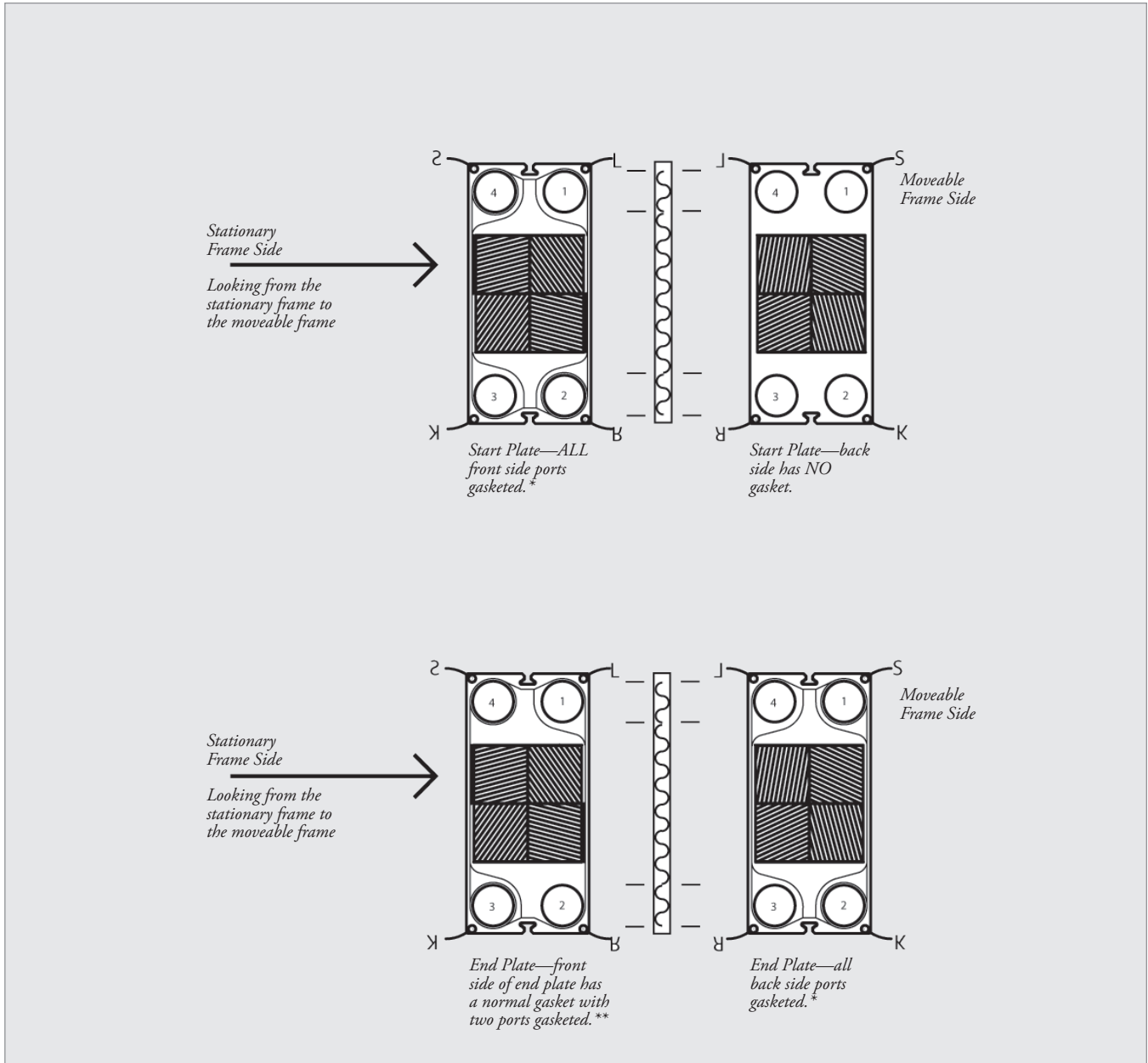

Figure 38

\* These gaskets are half thickness and may be pieced together in various ways depending upon specific model. Flow direction (i.e., Diagonal/Parallel) is not a factor for these gaskets.

\*\* This gasket will be the same as all non-Start/End plate gaskets. It will have two ports closed by the gasket. Which ports will be determined by the flow direction (Diagonal/Parallel). Diagonal flow is shown in these illustrations.



# INSTALLATION

## Unpacking

SUPERCHANGER units (with optional shroud) are bolted to and shipped assembled on a skid. Other optional items, if supplied, are packed separately. All items should be checked against packing lists.

SHOULD ANY PARTS BE MISSING OR DAMAGED, IMMEDIATELY NOTIFY:

**Tranter, Inc.**  
P.O. Box 2289  
Wichita Falls, TX 76307  
940-723-7125

## Recommended Procedures

All frame models are provided with special lifting eyeholes for transportation and installation by crane. Rigidly set all models on the floor by means of foundation bolts. The following installation tips are also recommended:

1. Level the unit.
2. Locate the unit in an area that is not congested with piping and other equipment. For units with nozzles on the movable frame, refer to Figures 39 and 40 on page 29.
3. Provide three feet of working area around the unit.
4. The piping system must allow for thermal expansion. This can be accomplished inherently within the piping layout or by flexible connections.
5. Debris can cause damage to the gaskets. The gasket areas must be free from sand, gravel, pieces of iron, etc. before the unit is closed.
6. Lubricate the tie bolts.
7. Tighten all tie rod nuts. Tighten the unit to plate pack dimension per assembly drawings prior to making any assembly connections.
8. Uniformly tighten the plate pack. (See tightening instructions following.)
9. Flush connecting piping of all debris prior to "hook-up" with the heat exchanger.
10. Correctly center gaskets inserted between pipe flanges.
11. Do not apply valve and piping loads to the nozzles. Use pipe supports.
12. Install shutoff valves at all nozzle locations.
13. Place vent valves for draining at the highest possible point.
14. Provide pumps sending liquid into the SUPERCHANGER with throttling valves.
15. Install a safety relief valve if the maximum pressure output of the pump is greater than that of the heat exchanger.
16. When a pressure control valve is installed, place it at the inlet of the heat exchanger, even if a pressure control switch is provided.

**CAUTION: Do not expose plate and frame heat exchangers to continuous vibration and/or high frequency cyclic on/off operation since damage from fatigue may occur. Do not use metering and pulsating type pumps. If the SUPERCHANGER unit is used in cyclic operation, the equipment should be tightened to the minimum dimension (see Table 3) to prevent fretting failure. Contact the factory for assistance.**

## Tightening the Plate Pack

The plate pack tightening length (distance between the facing surfaces of the “S” and “E” frames) is given on the assembly drawing and on the unit data plate. The tightening dimension is identified as “A Max.” and “A Min.” The unit is normally tightened at the factory to the average dimension between “A Max.” and “A Min.” “A Min.” is a minimum length. Consult the SUPERCHANGER Engineering Department before tightening the unit to a smaller dimension. **CAUTION: On units operating in excess of 200 psig, the tightening dimension is to equal or approach the minimum dimension.** The wrench size required for the various SUPERCHANGER tightening bolt diameters is shown below. Refer to the SUPERCHANGER drawing for the actual bolt diameter.

BOLT DIAMETER (in.)	WRENCH SIZE (Across Flats) (in.)
3/4	1 1/4
1	1 5/8
1 1/4	2
1 1/2	2 3/8
1 3/4	2 3/4
2	3 1/8
2 1/4	3 1/2
2 1/2	3 7/8

Due to manufacturing tolerances, a unit is sometimes shipped with a plate pack dimension greater than the minimum dimension stated on the drawing. If leakage occurs, after a period of time, tighten the unit to the minimum length. If the plate pack length is shorter than the minimum length, damage to the plates at contact points may result. If leakage occurs at the minimum length, contact the SUPERCHANGER Engineering Department for recommendations regarding gasket replacement or additional tightening.

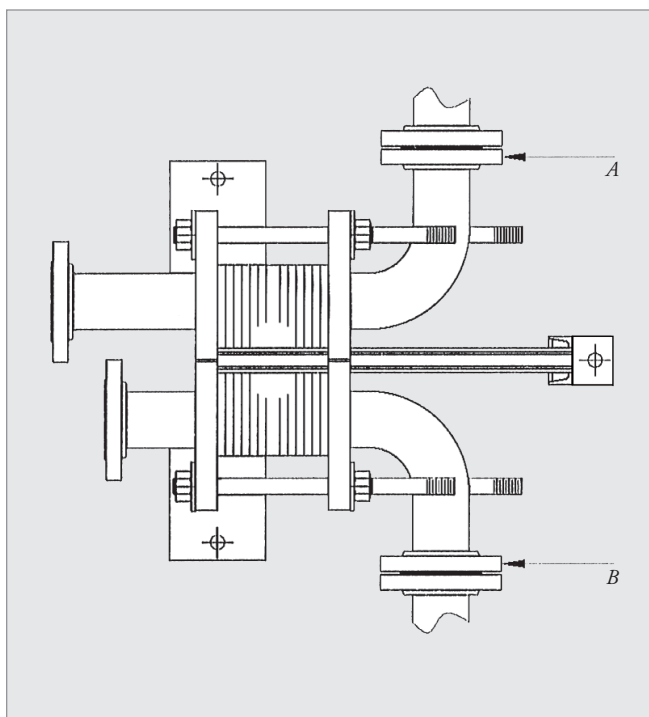

Figure 39  
Correct piping installation—disconnecting A and B connections will permit movement of the end frame (top view).

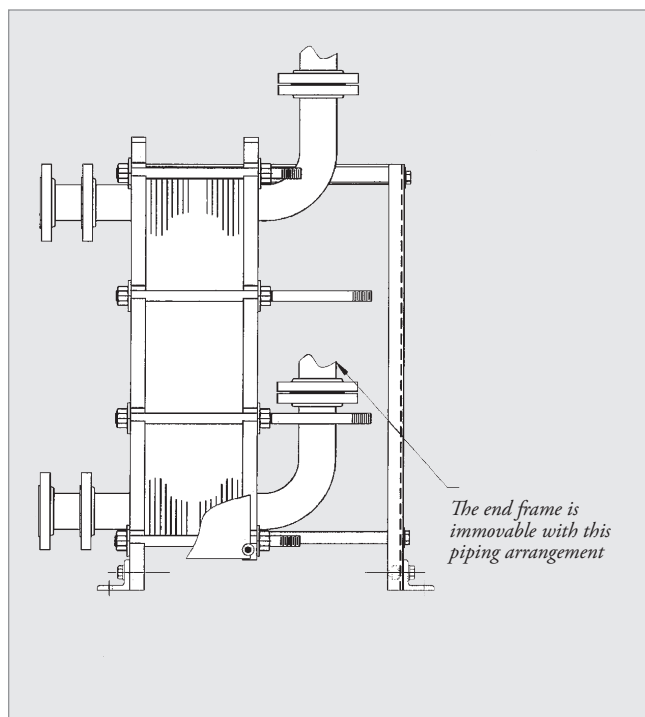

Figure 40  
Incorrect piping installation—the end frame is immovable (side view).

An EZCHANGER Hydraulic Closing Device is available for assembly/disassembly of larger units. See page 45 for details.



## Tightening Sequences

Figure 41 gives the tightening sequence for all units. When facing the stationary frame, tighten using the 1, 2, 3 and 4 bolts in sequence as far as possible before installing the remaining bolts. Be careful to tighten uniformly so that the moveable frame is kept parallel with the fixed frame within 1/4 in. Check the plate pack length on both sides of the plate pack at all tightening bolt locations. Tighten the unit, according to this procedure, to the plate pack dimension stated on the assembly drawing or unit data plate. Measure the dimension with a metal tape and tighten all bolts within 1/32 in. of the “A” dimension. (See Table 3.)

**WARNING: Do not tighten the plate heat exchanger when it is holding liquid, under pressure or operating. Rupture of the gaskets and exposure to physical injury may occur. Always cool and drain the heat exchanger before tightening.**

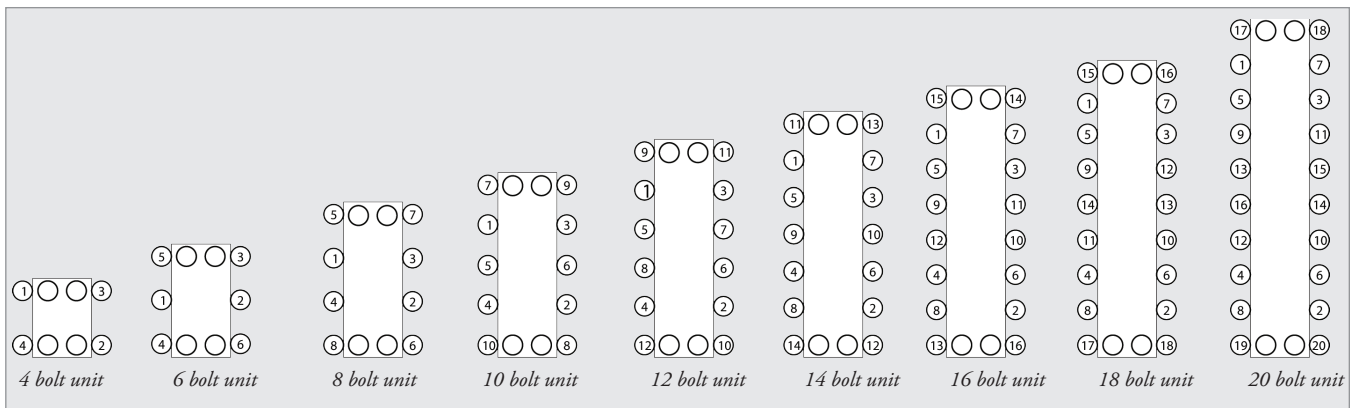

Figure 41  
Tightening sequence for all units.

## START-UP PROCEDURES

### Precautions Prior to Start-Up

1. If there is particulate matter in the process streams, contact your Tranter sales/service office to determine if a pipeline or in-port strainer should be used before operating the unit.
2. Confirm that the plate pack length is correct.
3. Open all outlet valves completely.
4. Completely close the pump discharge valves to the heat exchanger.
5. Provide venting on both sides of the heat exchanger to facilitate the removal of air from the system.
6. Start pumps and increase the pressure by opening the pump discharge valve slowly.
7. When all air is out, liquid will flow out of the vent. Close the vent.
8. Slowly and simultaneously open the inlet valves for both fluids to avoid extreme over-pressure due to hydraulic shock.
9. Control the amount of heating or cooling by using throttling valves and product thermometers in conjunction.

**CAUTION: To reduce the possibility of water hammer, do not use fast opening and closing valves. The pressure surge caused by a sudden change in the fluid velocity can be several times higher than the normal operating pressure of the system.**

## SERVICING

### Shutting Down the Unit

1. Gradually decrease the pressure of both fluids simultaneously until all pressure is relieved.
2. Never open a superchanger unit when it is hot. Cool the unit to a warm temperature before opening to prevent personal injury and gasket loosening.
3. Completely drain fluids from the unit.

### Disassembly Procedures

To open the exchanger, it is necessary to disconnect all connections (if any) to the “E” moveable frame. Lubricate all bolts prior to disassembly. Then completely loosen and remove all bolts except those indicated by a “filled circle” in the sketch below for the size unit involved. The four remaining bolts can then be loosened in any left-right sequence at 1/4 in. increments until they can be lifted out.

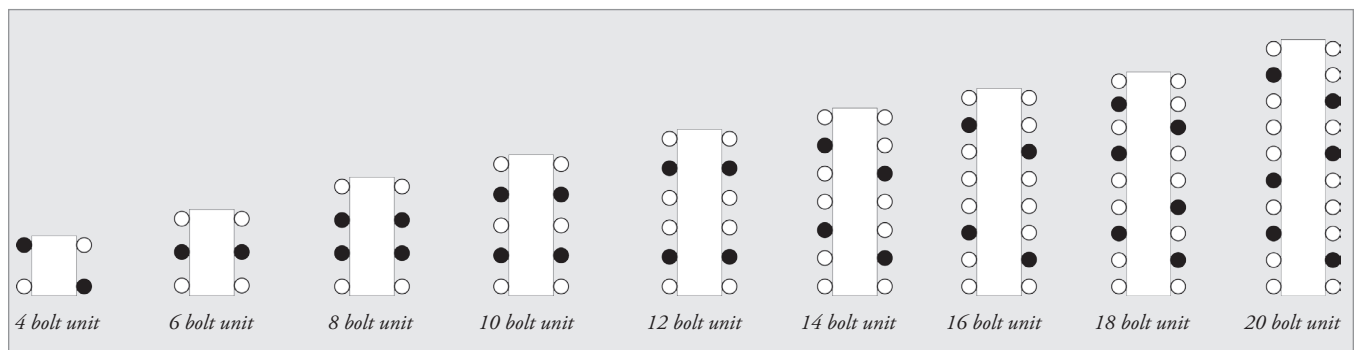

Figure 42  
Loosening sequence.

### Removal of Plates

**CAUTION: Exercise care when handling plates. The edges are sharp. Leather gloves must be worn.**

1. Remove the plates one by one from the frame.
2. Clean and/or inspect the plates hanging in the frame by removing them one at a time.
3. To remove a plate from the frame:
  - (a) For UXP-005, UXP-010, UXP-100, SXP-070, SXP-400, SXP-140, GC, GX and GFP-050, GFP-100 and GFP-150 Series, tilt the plate and remove it.
  - (b) GFP-030, GFP-080, UXP-200, UXP-060, UXP-400 and UXP-110 Series, lift the plate, push down on the hanger to release it, tilt the plate and remove it.
  - (c) UXP-801 and UXP-802 Series, remove the sectional guide bar track, which is bolted into the bottom of the upper I beam near the moveable end. Tilt the plates and remove them one at a time. (There are three of the removable track sections along the guide bar length to facilitate plate removal.)

## Replacing Plates

A faulty plate can easily be removed and replaced by a spare plate. Check that the new plate has the holes and gaskets arranged in the same way as the faulty one, and that the hangers are arranged in the same direction as the original installation. When the plates are properly assembled, the edges form a “honeycomb” configuration as seen in Figure 43.

If a four-hole plate is defective and no spare plate is available, the defective plate and one adjacent four-hole plate can be removed. The capacity of the plate heat exchanger is then reduced, but usually only slightly. When plates are removed calculate new “A” tightening dimensions from Table 3.

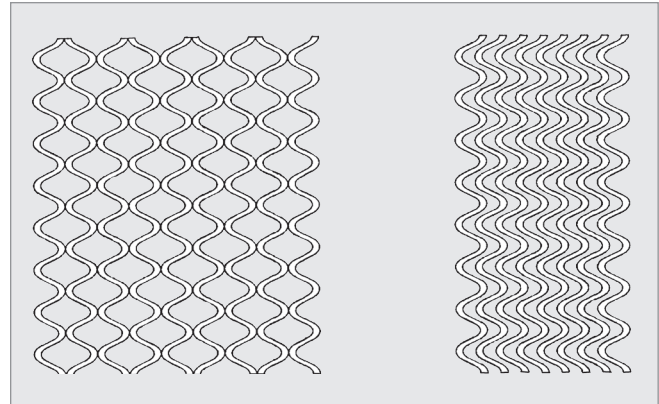

Figure 43  
Plate assembly.

## Replacing Gaskets

See Figures 4, 5, 6, 7 and 36.

### Removing Old Gaskets

When a gasket requires replacement, steps A1, A2 and A3 may be followed or alternately steps B1, B2 and B3 may be used if facilities are available.

- A1. Remove the plate from the frame and lay it on a clean, flat, horizontal surface. Examine and note exactly how the gasket is positioned on the plate, particularly what grooves the gasket does and does not occupy.
- A2. Insert a pointed tool (screw driver) under the gasket until a finger can be inserted. Then pull slowly until the gasket is removed.
- A3. Clean the gasket groove. Adhesive residue, oil, grease and other foreign matter can be removed by applying a solvent such as Methyl Ethyl Ketone (MEK), Acetone or other Ketones with a nylon or stainless steel brush. Commercial paint stripping compounds are also effective in removing the gasket adhesive. Dry/wipe the gasket groove. (NOTE: Use all solvents at room temperature (70°F) and in a well ventilated area not exposed to open flame, electric motors, etc.) Torches, grinding wheels and powered steel wire brushes are not to be used to remove adhesive residue since such tools will damage the plates.
- B1. When a gasket requires replacement, remove the plate from the frame and lay it on a clean, flat, horizontal surface. Examine and note exactly how the gasket is positioned

on the plate, the orientation of the bleed grooves and particularly what grooves the gasket occupies.

- B2. For gasket removal, immerse the plate assemblies in a 10% to 15% caustic bath solution at 140°F to 180°F for approximately 8 hr. The caustic will soften the glue and the gaskets can be removed. Brushing with a nylon brush will help remove the softened residual glue. (NOTE: Soak time will vary depending on the type of service and the length of exposure that the plates have seen.)
- B3. The caustic solution will normally remove most of the residue scale buildup on the heat transfer surface. Brushing with a nylon brush will help remove excess residue. Always rinse thoroughly.

To remove spot-glued gaskets, follow steps A1, A2 and, if necessary, step A3.

Remove scale deposits, such as calcium compounds, by immersing the plates in a 5% to 10% nitric acid solution at room temperature (70°F). This procedure must be followed by a thorough rinsing. See “Plate Cleaning Tips” on page 38.



## Installing Continuously Glued Gaskets

1. Make sure the gasket groove area is clean and dry prior to regasketing.
2. Apply a uniform layer of adhesive in the appropriate gasket grooves. (A plastic bottle makes an ideal applicator, provided the tip of the applicator is designed to provide a bead that is approximately 1/8 in. wide.) Do not apply adhesive in amounts that will allow it to ooze out when the gasket is pressed into the groove. Apply adhesive at room temperature (70°F). After the glue is applied to the plate, it should be allowed to set for a minimum of 30 sec before the gasket is set in place. Work on pairs of plates to allow for this curing time.

The recommended adhesive for all elastomeric gaskets is Pliobond 30. Pliobond 20 and 3M 1347 can also be used, if Pliobond 30 is not available. Hardening adhesives are not to be used. The number of gaskets that can be glued from one pint bottle of Pliobond 30 glue may be approximated as in Table 10.

3. Position the gasket on the plate making sure that the recess in the gasket at the bleed passage location is up. Also, when the proper side is up, the gasket code number will be visible in the bleed passage area. Proper groove fit and flow diverter access is dependent on end-to-end positioning. (See Figures 15 and 32.)
4. Using finger pressure, firmly press the gasket into the same grooves from which the original gasket was removed.
5. Compress the gasket by placing the plate under a weighted

sheet of wood. The longer the compression time, the better the bond. Twelve hours cure time at room temperature (70°F) should be allowed to assure minimum required adhesion of the gasket to the plate for all elastomers except EPDM. EPDM gaskets require a minimum of 24 hr cure time at room temperature (70°F) to assure an adequate bond. (When several plates are being gasketed, they can be stacked on top of each other with the weighted wood sheet placed on the top plate of the stack.)

6. After compression time (step 5), use solvent to remove any excess adhesive that may have seeped out past the edges of the gasket.
7. Reinstall plate(s) in the unit insuring that the gasket surface and the sealing surface of the plate ahead are wiped clean to provide a positive seal.

**NOTE: Refer to page 24 when using mixed gaskets.**

8. Note that the “D” plate (always the plate next to the fixed frame end) requires different gaskets. The purpose of the “D” plate is to prevent fluid from flowing across the fixed end frame. The only sealing surface on the “D” plate is the port hole gaskets. “D” plate gaskets for the UX series consist of two half gaskets. “D” plate gaskets for the GFP-030 and GFP-080 plates consist of four port hole gaskets and straight strips, which fit in the gasket groove around the periphery of the plate. The wide port gasket fits the widest groove, and the narrow port hole gasket fits the narrow groove.

**Table 10** Glue Requirements

MODEL	NUMBER OF GASKETS/PINT
XP-005	122
UXP-010	100
UXP-100	85
UXP-200	60
GFP-030	50
UXP-060, SXP-070	35
UXP-400	30
UXP-110	30
SXP-400, SXP-140	30
GFP-080	25
UXP-801, UXP-802	10
GXD-006	50
GXD-012, GL-013, GC-016	50
GXD-018, GCP-010	35
GXD-026, GCP-026	30
GXD-042	20
GXD-051, GCP-051	17

MODEL	NUMBER OF GASKETS/PINT
GXD-037	30
GXD-064	18
GXD-091	15
GXD-118	13
GXD-060, GCP-060	20
GXD-100	18
GXD-140	14
GXD-180	15
GXD-085	16
GXD-145	14
GXD-205	12
GXD-265	10
GXD-325	8
GFP-057	19
GFP-097	18
GFP-187	15
GL-230, GL-330, GL-430	8, 7, 6



## Installing Spot-Glued Gaskets

### Spot gluing of Elastomeric gaskets is covered under Tranter's U.S. Patent #5070939.

In the following procedure, after the glue is applied to the plate at the appropriate spots, allow it to set for a minimum of 30 sec before the gasket is mounted. Work on pairs of plates to allow for this curing time. Work in a well-ventilated area.

1. Clean the gasket groove in one plate with a rag moistened with Methyl Ethyl Ketone (MEK).
2. Apply a 1/8 in. diameter spot of Pliobond 30 approximately every 4 in. centered in the gasket groove of the plate just cleaned.
  - a) Apply the glue so there are no thin spots.
  - b) Apply spots of glue at the "T" joints (see Figure 44).
3. Clean the groove of a second plate, as in step 1.
4. Apply adhesive to the second plate, as in step 2.
5. Install the gasket on the first plate. Make sure the gasket is oriented as shown in Figures 15 and 32.
6. Install the gasket on the second plate, as in step 5.

**NOTE: The purpose of working with two plates simultaneously is to allow the adhesive to set for a minimum of 30 sec before the gasket is applied. When working with small plates, a third plate can be incorporated into the above procedure to obtain set time. The curing time must not exceed 3 min.**

7. Compress the gasket by placing the plate under a weighted sheet of wood. The longer the compression time, the better the bond. Twelve hours cure time at room temperature (70°F) should be allowed to assure maximum adhesion of the gasket to the plate for all elastomers except EPDM. EPDM gaskets require a minimum of 24 hr cure time at room temperature (70°F) to assure an adequate bond. (When several plates are being gasketed, they can be stacked on top of each other with the weighted wood sheet placed on the top plate of the stack.)

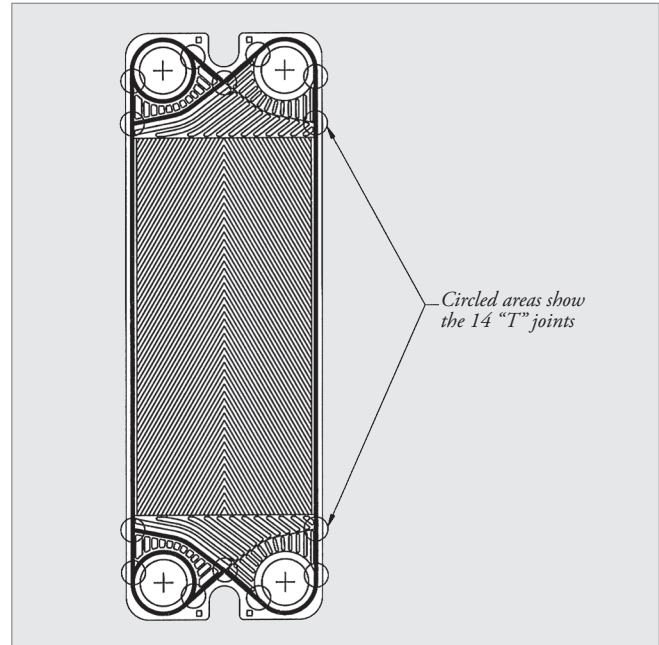

Figure 44  
Locations at "T" joints where glue must be applied.

**NOTE: Refer to page 24 when using mixed gaskets.**

8. After adequate compression time, use solvent to remove any excess adhesive that may have seeped-out past the edges of the gasket.
9. Reinstall plate(s) in unit insuring that the gasket surface and the sealing surface of the plate ahead are wiped clean to provide a positive seal.



## Installing SUPERLOCK® Snap-In Gaskets

**SUPERLOCK gaskets are covered under Tranter's U.S. Patent #4995455.**

1. Position the gasket on the plate making sure that the recess in the gasket at the bleed passage location is up. When the proper side is up, the gasket code number will be visible in the bleed passage area. Correct end-to-end position is also important for a proper groove fit and fluid access to the flow diverter. (See Figures 15 & 32.)
2. Make sure that the tabs of the SUPERLOCK gaskets are lined up with the slots in the gasket groove of the plate.
3. Insert each tab inside its corresponding slot and push firmly until the tab locks into the slot. Make sure that each of the porthole tabs (located in the bleed port area towards the middle of the plate) is also snapped into its slot.

**NOTE: Refer to page 24 when using mixed gaskets.**

## Installing Teflon Encapsulated Gaskets and Unit Assembly

**CAUTION: On units operating in excess of 200 psig, the tightening dimension is to equal or approach the minimum dimension.**

1. Install double-sided tape in the center of the gasket groove. Use continuous strips. Do not contaminate the tape surface.
2. Do not overlap tape strips as this will cause leakage in that area.
3. Install Teflon such that bleed ports (notches) in each section in rubber core are installed in the up position.
4. Install plates per the assembly drawing that is received with the unit.
5. Check top surface of Teflon and gasket seal surface for cleanliness.
6. Install all bolts and tighten the unit (snug tight only).
7. Refer to page 30 for tightening sequence.
8. Tighten unit in 1/16 in. increments to ensure even compression of gaskets.
9. Tighten to maximum dimension as shown on assembly drawing.
10. Single side hydrostatic test to design pressure shown on assembly drawing.
11. Double side hydrostatic test to test pressure shown on assembly drawing.
12. If unit leaks during either of the above tests, run 150°F to 170°F hot water for one hour. Let the unit cool and tighten to average dimension as shown on assembly drawing using same increments as in step 8.
13. Re-conduct the hydrostatic test.
14. If unit still leaks, mark plate and area of leakage.
15. Disassemble unit and check gasket and seal surface for defects, especially at the leakage sites. If no apparent defect is found, apply an even thin layer of "Teflon TFE Pipe Thread Sealer," furnished by McMaster Carr ([www.mcmaster.com](http://www.mcmaster.com), part #4538K1), to Teflon gasket at leakage site.
16. Retighten unit using same procedure as listed above.
17. Re-conduct the hydrostatic test.
18. Unit should not seal. If unit is still leaking, contact the factory.

**NOTE: Refer to page 24 when using mixed gaskets.**





### Installing Clip-On Gaskets

There is one kind of channel arrangement. The first, uneven and last channel will always be S2/S4. The even channels will always be S1/S3. The Tranter standard connection location is hot in/out S1/S3. Therefore, it will start and end with a cold channel. If a hot in/out in S2/S4 is required, the first and last channels will subsequently be hot.

1. Attach half-A gasket to the start plate in the RORU orientation, as in Figure 46. Hang by the ORU orientation, as shown in Figure 45.
2. Attach B gaskets to even plates by the LOLU orientation. (See Figure 46.) Hang by the ORD orientation, so the “O” is in the lower right corner. (See Figure 45.) This is equivalent to Channel B.
3. Attach A gaskets to odd plates by the RORU orientation, as shown in Figure 46. Hang by the ORU orientation, as in Figure 45. This forms a Channel A.
4. Attach B gasket to end plate by the LOLU orientation, and attach half-A gasket to the backside of the end plate by the RORU orientation. (See Figure 46.) Hang by the ORD orientation with B gasket facing inside. (See Figure 45.) This completes the plate pack.

The following is an example of the above in a GLD-013 heat exchanger:

#### Plate Hanging Assembly

PLATE SEQUENCE	ATTACHING	HANGING
1	RORU Start	ORU
2, 4..54, 56	LOLU	ORD
3, 5..55, 57	RORU	ORU
58, 60..70, 72	LOLU	ORD
59, 61..71, 73	RORU	ORU
74	LOLU End	ORD

#### Gasket Attaching Assembly

QUANTITY	ATTACHING
1	RORU Start
28	LOLU
36	RORU
8	LOLU
1	LOLU End

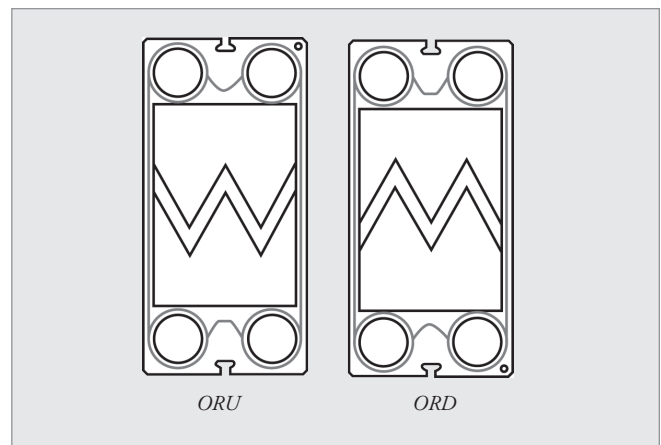

Figure 45  
Plate hanging orientation.

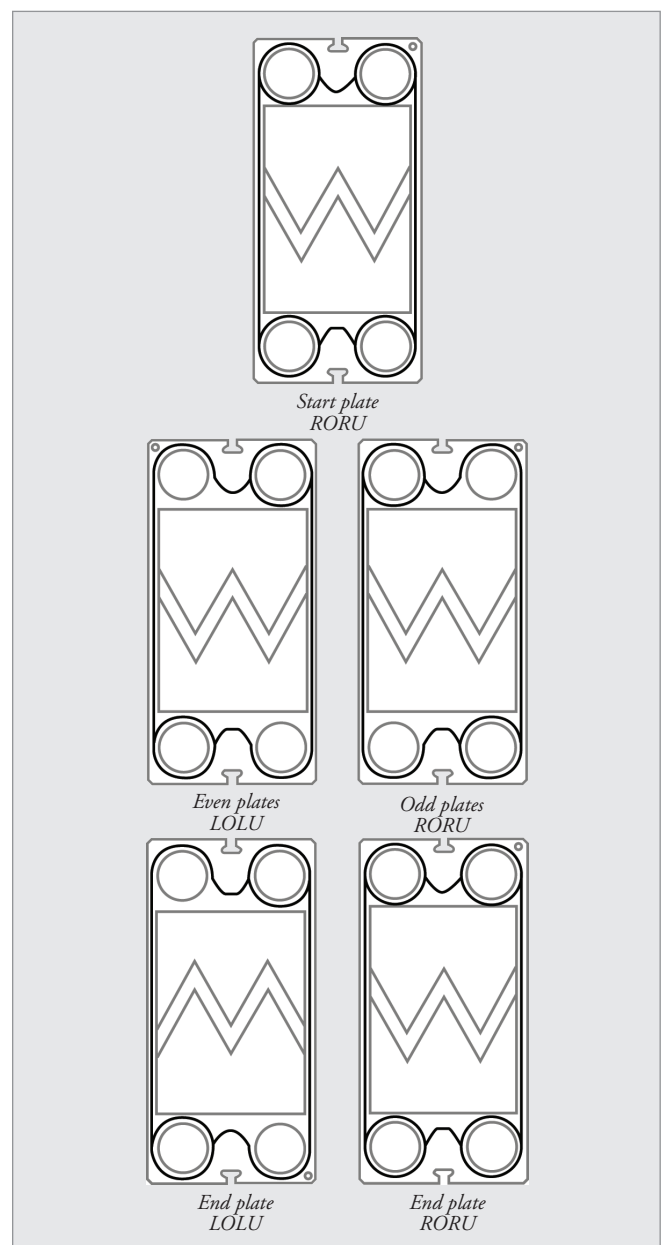

Figure 46  
Gasket attaching orientation.



## CLEANING

SUPERCHANGER plate and frame type heat exchangers are designed for both manual cleaning and cleaning-in-place operations. Where possible, utilize a cleaning-in-place system that will allow pumping water or cleaning solutions into the unit without disassembling. A CIP system may be purchased through Tranter. If this is not feasible, use the manual method. Descriptions of the two cleaning procedures follow.

### Steps for Manual Cleaning of Plates

1. Open the unit in accordance with disassembly procedures on page 31.
2. Clean each plate separately. Depending upon the amount of cleaning to be performed, the plate can be cleaned while still hanging in the unit or removed, placed on a flat surface and cleaned.
3. **Never use a steel brush or steel wool on the plates.** If a brush is required, use one with bristles that are softer than the plate material. If iron is forcibly rubbed on a stainless steel surface, it is impossible to remove all imbedded particles and will result in accelerated rusting and/or corrosion. If it is absolutely necessary that a metal brush be used, the brush material must be compatible with the plate material.
4. Be careful not to scratch the gasket surfaces.
5. After brushing, each plate should be rinsed with clean water.
6. Use high pressure rinse when cleaning continuously glued plate assemblies.
7. See “Plate Cleaning Tips” on page 38 for specific types of deposits.
8. **The gaskets must be wiped dry with a cloth.** Solid particles adhering to the gaskets cause damage and result in leakage when the unit is put back in operation.
9. The lower portion of each plate as hung in the unit should be inspected carefully and cleaned appropriately as this is the primary area where residual solid material tends to accumulate.
10. Wipe off the mating surface, i.e., the rear of the plate where the gasket seats.
11. Upon completing the cleaning, inspection and installation of each plate, the unit may be closed, tightened per the assembly drawing and the tightening instructions (page 30), and placed into operation.

**CAUTION: Do not use chlorine or chlorinated water to clean stainless steel, Hastelloy, Incolloy, Inconel and 254SMO. Chlorine is commonly used to inhibit bacteria growth in cooling water systems. It reduces the corrosion resistance of stainless steel, Hastelloy, Incolloy, Inconel and 254SMO. The “protection layer” of these steels is weakened by chlorine and makes them more susceptible to corrosion. This increase in susceptibility to corrosion is a function of time and the chlorine concentration. For any applications where chlorination must be used with non-titanium equipment, please contact the factory.**

## Plate Cleaning Tips

1. Do not use hydrochloric acids, or water containing in excess of 300 ppm chlorides, with stainless steel.
2. Do not use phosphoric or sulfamic acid for cleaning titanium plates.
3. Limit cleaning solution concentration to 4% in strength, with temperatures not exceeding 140°F unless otherwise specified.

General guidelines for cleaning are tabulated below. (Please refer to steps 1 through 3 above for precautions.)

TYPE OF FOULING	SUGGESTED CLEANERS
Calcium Sulphate, Silicates	Citric, Nitric, Phosphoric or Sulfamic Acid
Calcium Carbonate	10% Nitric Acid (1 volume concentrated Nitric Acid with specific gravity 1.41 to 9 volumes of water), Oakite 131
Alumina, Metal Oxides, Silt	Citric, Nitric, Phosphoric, or Sulfamic Acid (To improve cleaning, add detergent to acid.)
Barnacles, Mussels, Seaweed, Wood Chips	Back flush per cleaning-in-place procedure below and Figure 48
Biological Growth	Sodium carbonate or sodium hydroxide

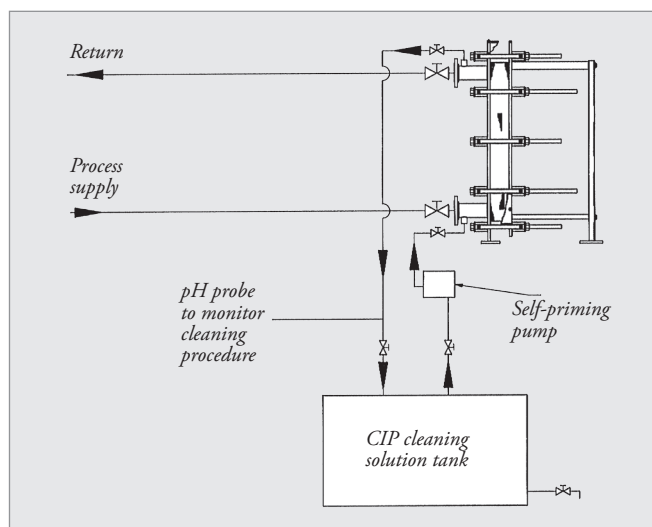

Figure 47  
Cleaning-in-place flow chart.

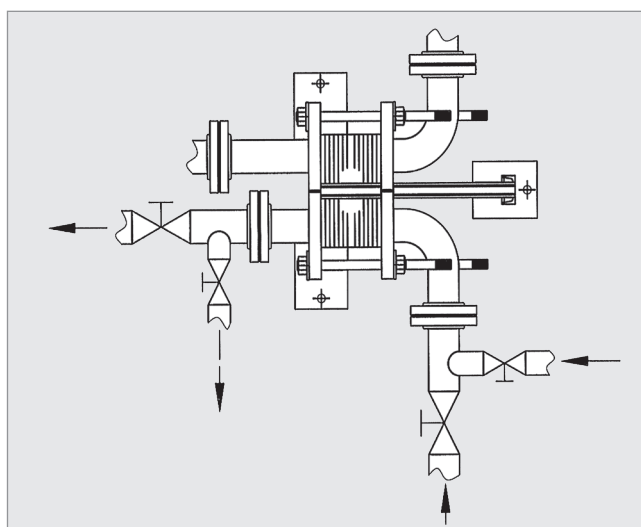

Figure 48  
Piping using brine (top view).

## Cleaning-In-Place (CIP)

Cleaning-in-place is the preferred cleaning method when especially corrosive liquids are processed in a SUPERCHANGER unit. Install drain piping to avoid corrosion of the plates due to residual liquids left in the unit after an operation cycle. (See Figure 47.)

To prepare the unit for cleaning, follow the procedures listed below:

1. Drain both sides of the unit. If it is not possible to drain, force liquids out of the unit with flush water.
2. Flush the unit on both sides with warm water at approximately 110°F until the effluent water is clear and free of the process fluid.
3. Drain the flush water from the unit and connect CIP pump. (See “Plate Cleaning Tips” above for suggested cleaners.)
4. For thorough cleaning, it is necessary to flow CIP solution bottom to top to insure wetting of all surfaces with cleaning solution. When cleaning multiple pass units,

it will be necessary to reverse flow for at least 1/2 the cleaning time to wet all surfaces.

5. For optimum cleaning, use the maximum flow rate of water, rinse, or CIP solution that the CIP nozzle size will allow (2 in. @ 260 gpm, 1 in. @ 67 gpm.) A CIP operation will be most effective if performed on a regularly scheduled basis and before the unit is completely fouled.
6. Flush thoroughly with clean water after CIP cleaning.

**CAUTION: If brine is used as a cooling medium, completely drain the fluid from the unit and flush the unit with cold water prior to any cleaning operation. Corrosion will be kept at a minimum if all traces of brine are eliminated before using hot cip solutions on either side of the heat exchanger.**



## Back Flushing and Strainers

Often, when fibers or large particulates are present, back flushing of the unit proves to be very beneficial. This is accomplished by either of the following methods:

1. Flush the unit with clean water in reverse flow pattern to the normal operating direction.
2. Arrange piping and valves so the unit may be operated in reverse flow mode on the product side for fixed periods of time. This method is particularly well suited for steam-to-product units.
3. The use of strainers are recommended in supply lines ahead of the exchanger when the streams contain significant solids or fibers. This will reduce the requirements for back flushing.

## Cleaning Guidelines

1. Never open the unit when hot, under pressure, holding liquid or operating.
2. Never clean the plates with a steel brush or steel wool.
3. Always wipe the gaskets clean before closing the unit to prevent damage resulting from adhering particulate matter.
4. Always use clean water (free from salt, sulphur, chlorine or high iron concentrations) for flushing and rinsing operations.
5. If steam is used as a sterilizing medium, do not exceed 270°F steam temperature with nitrile gaskets and 350°F with EPDM gaskets.
6. If chlorinated solutions are used as the cleaning media, employ a minimum concentration at the lowest temperature possible. Minimize the plate exposure time. The chlorine concentration must be less than 100 ppm and temperatures must be under 100°F with a maximum plate exposure time of 10 min. Follow the cleaning recommendations of suppliers, relative to concentration, temperature and treatment time.
7. Always add concentrated cleaning solutions to water before circulating through the unit. Never inject these solutions while the water is circulating.
8. Remove rusted or pitted areas that appear on the plates with commercial scouring powder. Follow this by flushing with clean water.
9. Cleaning solutions should always be circulated with a centrifugal pump.
10. Do not use hydrochloric (muriatic) acid for cleaning plates.
11. Thoroughly rinse the plates with clean water following any type of chemical cleaning.

# TROUBLESHOOTING

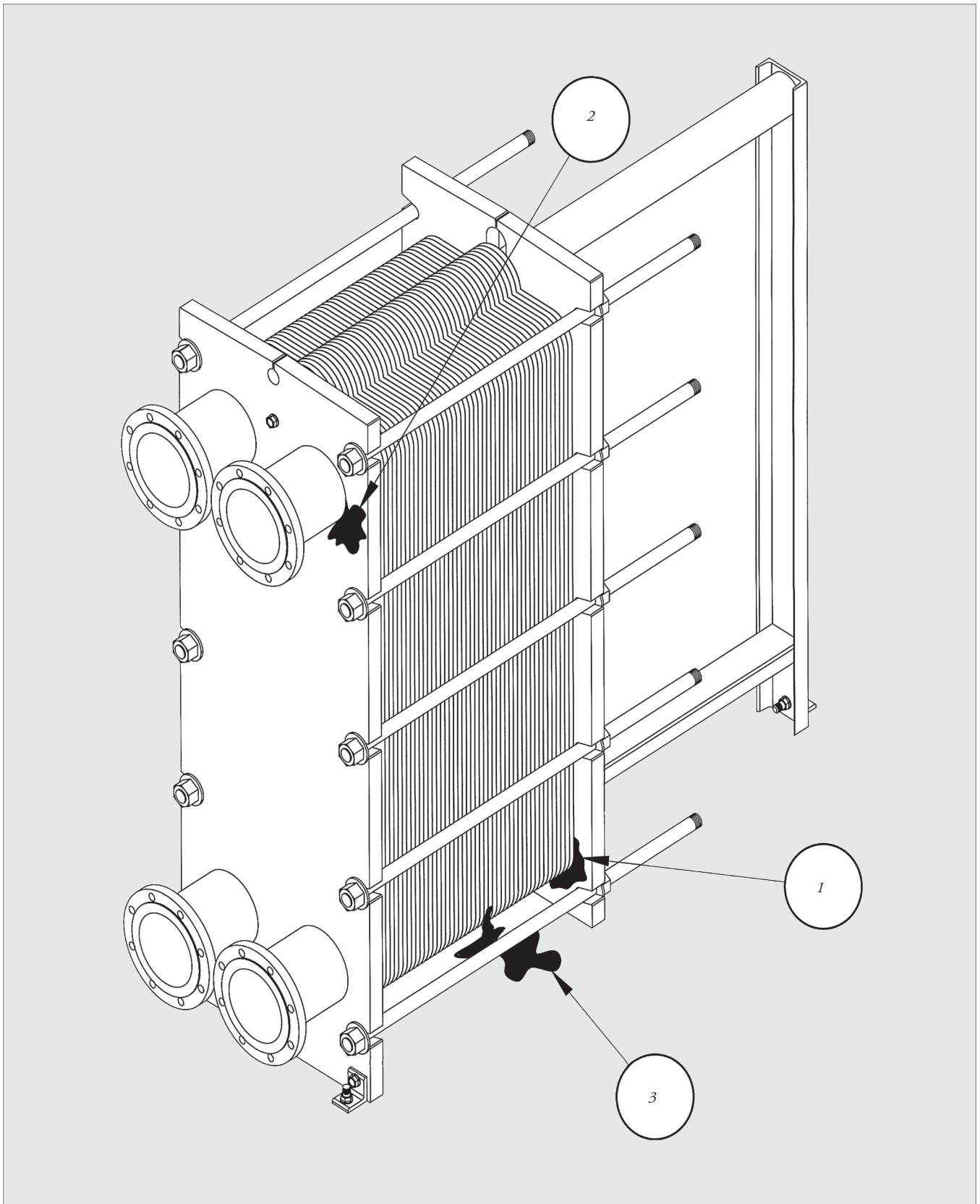

Figure 49  
*Troubleshooting sources of leaks.*

## Leakage Between the Plate Pack and the Frame

(See Figure 49, Item 1)

PROCEDURES AND OBSERVATIONS	SOLUTIONS
1. Use a felt tip marker to identify the area where the leakage seems to be occurring and then open the plate pack.	
2. If the leakage occurs in the area of a nozzle, then observe the gasket condition of the “D” plate or “E” nozzle “O” ring. Foreign matter, scars, other damage to the gasket surfaces and any gasket dislocation may be the problem.	Remove all foreign matter, relocate the gasket, or replace the damaged gasket.
3. Check the end frame for foreign objects, surface unevenness, or any other condition which might interfere with the seal between the gasket and the adjacent surface.	Remove any interference between the gasket and the surface of the end frame.
4. Check the plate for cracks or holes.	If a plate has perforation, it must be replaced.

## Leakage Between the Nozzle and the End Frame

(See Figure 49, Item 2)

PROCEDURES AND OBSERVATIONS	SOLUTIONS
1. Fluid is flowing from the area between the nozzle and the end frame (point A on Figure 50) and/or the interior of the end frame and the seal plate (point B on Figure 50).	Check the integrity of the continuous pressure weld between the stub end and the seal point (point C on Figure 50). Dye-check for small cracks. If the dye-check reveals any linear indication, the area needs to be ground down and re-welded using TIG welding, and the appropriate welding wire. If the weld damage occurred due to a blow to the nozzle, some of the plate assemblies may be damaged. Damaged plates should be replaced.

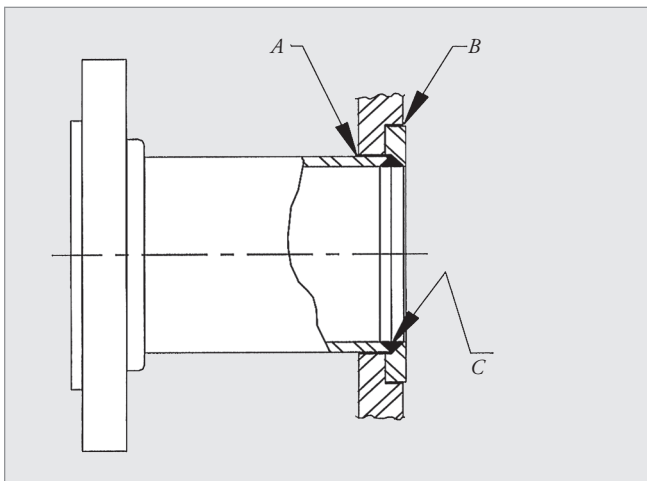

Figure 50  
*Troubleshooting nozzle/end frame leaks.*



## Leakage Between the Plates to the Outside of the Unit

(See Figure 49, Item 3)

PROCEDURES AND OBSERVATIONS	SOLUTIONS
1. Mark the area of the leak with a felt tip marker.	
2. Check the plate pack dimensions to insure they agree with Table 3. Overtightening may cause plate damage.	Depressurize unit and adjust the plate pack as necessary. Disassemble unit per procedure on page 31.
3. Look for mislocated, loose or damaged gaskets.	Relocate gaskets, reglue loose gaskets and replace damaged gaskets.
4. Check for plate damage in the area.	A damaged plate usually must be replaced. For temporary duty, if the damaged plate has four holes and an adjacent plate (front or back) has four holes, remove both plates and retighten the plate pack according to Table 3. Contact the factory if temporary operating characteristics need to be developed for a smaller number of plates. See “How to Find a Defective Plate” on page 43.
5. Make sure the plate pack sequence is A-B-A-B-etc., see Figure 15.	Inspect the plate pack for damage and place the plate assemblies in the correct order.

## Mixing of Fluids

PROCEDURES AND OBSERVATIONS	SOLUTIONS
1. Make sure the piping is connected to the correct locations on the heat exchanger.	Relocate piping to the correct connections.
2. Make sure the plates are properly arranged on each adjacent plate according to the assembly drawing (A-B-A-B... arrangement).	Open the plate pack and replace the plate gasket assembly.
3. Make sure the gaskets are correctly oriented on the plates with the “bleed port” of each gasket facing away from the plate surface. See Figures 32 through 34.	Replace gaskets correctly.
4. Follow the steps described in “How to Find a Defective Plate” on page 43. If a leak is found, use a felt tip marker to locate the place.	Remove and replace as discussed on page 33. Inspect the plate pack for damage and place the plate assemblies in the correct order.

## Increase in Pressure Drop or a Reduction in Temperature Reading

PROCEDURES AND OBSERVATIONS	SOLUTIONS
1. The pressure drop from the inlet to the outlet on one or both sides of the unit is too high compared to the original specified pressure change.	Try cleaning-in-place (CIP) as described in Figures 47 and 48. Check the accuracy of the instrumentation. Pressure taps should be installed 10 and 5 pipe diameters upstream and downstream, respectively, from flow disturbing source, i.e., elbow, valve, reducer, etc.
2. The temperature readings are correct for the process; however, the pressure drop is high.	The plate surfaces are clean enough, however, the inlet of the unit could be clogged. Back flushing the equipment or CIP may solve the problem.
3. The temperature readings do not correspond to the original temperature settings or specifications.	The pressure drop is probably also increasing. The change in the temperature readings indicates that there is a buildup of deposits on the plate surfaces. If CIP or back flushing the equipment does not work, the unit will need to be opened and the plates cleaned.
4. The pressure drop is too low, and the unit is known to be clean.	The pump capacity may be too small. Check the pump manual.

## How to Find a Defective Plate With Through Holes

Severe corrosion may cause defect to occur. The following method is recommended to determine the location of the defective plate or plates:

1. Open the unit, remove all fouling from surfaces and dry the plates after cleaning. Make sure the bleed port areas (see Figure 32) are clear.
2. After completely drying the plates, reassemble the unit.
3. Supply water to one side (“A” side) and raise the water pressure to approximately 50 psig.
4. Open the drain valve at the lowest point or break the flange on “B” side. By removing the flange and fittings, it is possible to look into the nozzle and measure to the exact leaking plate.
5. Stop the test if water flows out of the drain valve or flange on “B” side.
6. Open all valves and empty the unit of all water.
7. Open the unit promptly and find which plate is wet on “B” side. This plate and the preceding plates may have defects.
8. The defect can be found by placing a lamp on the rear side of the plate and by observing the light that passes through.
9. If the defect is small, the use of dye penetrant may be required to locate the defect. Because of the metal to metal contact of the plates, the defect can be larger when the plate pack is compressed than when it is in the free state.

**NOTE: A unit with multiple pass circuits that does not allow the fluid to drain out of each channel on one side cannot be tested in this way unless the special center plates are first removed. See Figure 20 as an example.**



## STORAGE PROCEDURES

When a SUPERCHANGER plate and frame heat exchanger is to be placed in storage for six months or longer, the procedures listed below must be followed:

1. If the unit has been recently shipped from our factory and is unused, disregard steps 2, 3 and 4; follow steps 5 through 10.
2. If the unit has been used and long-term storage is required, it must be completely drained. Prior to draining remove the optional shroud, if provided, and let the unit cool to ambient temperature. Units with plate packs arranged with one pass on each side (all nozzles on the stationary end frame) are self-draining. Simply vent at the upper nozzle location and drain from the lower nozzle for each side individually. A two pass/two pass or one pass/two pass plate arrangement is also self-draining, provided all two pass side nozzles are at the lower elevations (numbers S2, S3, M2 and M3). Other units may be self-draining if they have been fitted with separate drain and vent nozzles, or with vents and drain holes. Units that are not self draining must have the plate pack completely loosened to drain all liquids. Before opening the plate pack, wipe off the exterior surfaces to make sure no fluids or debris fall onto the plate pack.
3. Open the plate pack and thoroughly clean the unit internally and externally. Dry the unit. (Blowing dry, hot air at approximately 150°F on all areas is an excellent method.)
4. Install blind flanges with gaskets on all nozzles. Plug all other openings.
5. Coat all unpainted carbon steel component surfaces with light grease, SAE 30 oil or other rust inhibiting products.
6. Coat all bolt threads with light grease.
7. Loosening of the plate pack is not recommended. However, it is advisable that to avoid any compression set of the gaskets, the plate pack length dimension be adjusted. This should be greater than the unit's stated minimum tightening dimension (T.D.).
8. Protect the unit from direct sunlight, intense heat radiation or ultraviolet radiation by loosely covering the unit with an opaque, reflecting type plastic film or similar material. Make sure air is allowed to circulate around the unit.
9. It is preferable to store the unit indoors, well protected from the weather. The temperature in the storage area should ideally be 60°F to 70°F with a relative humidity of 70% or lower.
10. All potential sources of Ozone, such as operating electric motors or welding equipment, should be removed from the storage area to preclude Ozone attack on gaskets. Gaskets should not be exposed to direct sunlight (ultraviolet radiation) and should be stored in dark plastic bags. Under proper storage conditions, gaskets generally have a shelf life of approximately four years.

**CAUTION: Never store the unit in an area where the temperature is at 32°F or lower.**